

An effective imaging based diagnosis of Solar Photovoltaic System and performance parameters for smart solar power grid

Kirti Pathak^{1*}, Dr. Sanjay Kumar Jagannath Bagul²

¹ Research Scholar, University of Technology, Jaipur, Rajasthan

² Supervisor, University of Technology, Jaipur, Rajasthan

Abstract - Another of the most attractive power generation sources for residential, corporate, and commercial operations is energy production. Due to this compelling qualities, photovoltaic systems (PV) electricity production have increasingly attracted the attention of researchers and professionals. Nonetheless, the greatest obstacle in generating energy from the sun is the predictable discontinuous output power from photovoltaic (PV) systems, which is largely caused by climate. The power differential of a photovoltaic panels may considerably reduce the financial profit of large scale solar fields. For everyday proper management of electricity supply production, distribution, and storing as well as for judgement on the electricity market, results were consistent prediction of the electricity output of solar PV systems is essential.

The 5 subjects mentioned in this article are:

- ✓ The varied faults which might occur in PV panels; internet Photovoltaic panels monitoring;
- ✓ Use of machine learning approaches in Photovoltaic module damage detection;
- ✓ Advantages of fault diagnosis in PV panels and the various motion sensors used for this purpose are discussed.
- ✓ Recommendation for future possible research paths are given in view of the evaluated research.

Keywords - power generation, sources for residential, PV panels, machine learning, electricity output, large scale solar fields.

-----X-----

INTRODUCTION

Solar power is quickly becoming one of the most attractive alternatives to traditional grid electricity for residential, business, and industrial use. Solar photovoltaic (PV) systems use PV cells to generate electricity from sunlight. Photovoltaic (PV) energy, in particular, has gained appeal as a renewable energy source in recent years because of its low cost, long payback time, and high environmental and social benefits. One of the most widely used renewable energy sources; solar power is advantageous due to its low environmental impact, zero operating costs, and unlimited availability. This greatly accelerated the global rollout of solar photovoltaic (PV) systems.

Inaccurate estimates of solar panels' demise can be caused by environmental factors such as temperature, cloud cover, dust, irradiance level, and relative humidity. Problems with solar panels can lead to erratic behaviour in addition to reducing the effectiveness and reliability of the plant's services. The failure to properly prioritize fault detection can lead to power losses, and

when solar arrays are faulty, the entire system is at risk of failure. In grid-connected solar systems, failure detection using multiple methods is possible. Some of them use meteorological and astronomical information to spot problems in GCPV systems.

Use of electricity is now universally recognized as a need. As has been said, rising middle-class and urban populations are driving up the need for electricity across the world. Given that they are both non-renewable and polluting, fossil fuels have no place in a sustainable future. Consequently, we need to reduce our reliance on non-renewable resources, with renewable energy taking on a more crucial role in the future.

Accurate solar energy projections are critical for photovoltaic (PV) based energy plants to take part in energy auction markets early and to plan resources efficiently. The literature reports a plethora of techniques for predicting PV solar output. There are

essentially four distinct categories into which these strategies might be placed:

1. The use of data-driven statistical formulations for the purpose of predicting solar time series using archival measurements
2. The use of artificial neural networks and other forms of machine learning;
3. Physical models derived from numerical weather prediction and satellite imagery, and
4. Strategies that combine different aspects of the aforementioned approaches are known as hybrid approaches. The seasonal autoregressive integrated moving average (SARIMA), a hybrid model combining a random vector functional link neural network and the discrete wavelet transform, has been introduced as a means of predicting solar PV power generation over shorter time periods. The findings of the combined models have been found to be more accurate than those of the separate models.

Pv Systems In Energy Conversion

The efficacy of photovoltaic (PV) systems is heavily dependent on the effectiveness of solar radiation, temperature, and conversion. PV systems suffer from variable system performance, high installation costs, and low module efficiency of up to 20% as a direct result of weather fluctuations. This is in addition to the many other drawbacks that PV systems have. The optimization of the size of stand-alone or grid-connected photovoltaic systems (GCPVS) is a complex problem of optimization that predicts the acquiring of adequate energy and economic expenses for customers. With the right placement of photovoltaic (PV) panels, solar energy can be used practically everywhere, which is one of its many attractive selling points figure 1.1. In general, the following are some of the benefits of solar photovoltaic (PV) systems:

- Low environmental effects
- Capable of being conveniently placed near to the customer, hence decreasing the losses that occur along the transmission line



Figure 1: PV Systems in Energy Conversion

Photovoltaic system design

This section provides information on two different types of job altogether. In the first place, those works that are associated with the fundamental components of a photovoltaic system, and in the second place, those works that are associated with the configuration of solar power plants. Figure 1.2 depicts one possible approach to the design of solar systems, which may be found in the accompanying text.



Figure 2: Design of photovoltaic systems

Photovoltaic system operation

Work related to the general operation of solar systems, the operation of hybrid systems produced by photovoltaic systems, and the power quality issue will be provided in this section. Photovoltaic technologies and the problem of power quality combine to generate these hybrid systems. Figure 1.3 depicts one approach to understanding how photovoltaic systems function.

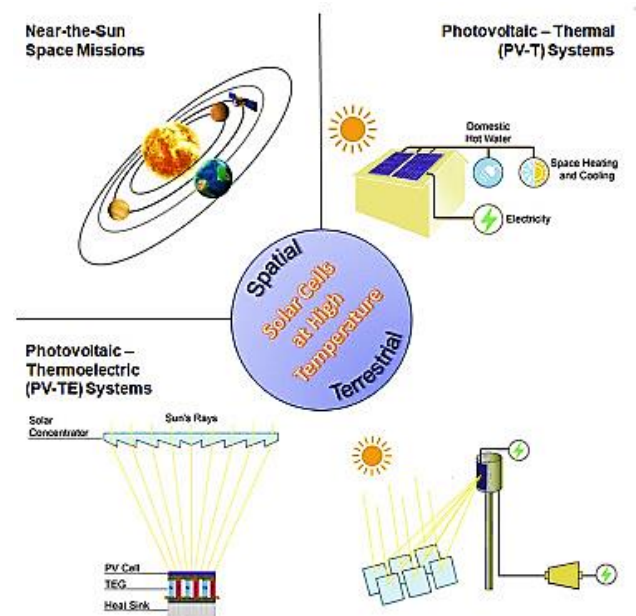

Figure 3: Operation of photovoltaic systems

POWER ELECTRONIC CONVERTERS IN RENEWABLE ENERGY CONVERSION

For the past several decades, scientists have been concentrating their efforts on the study of renewable energy sources, and now, various power inverters are being manufactured to link these technologies to the distribution system. In order to guarantee both the delivery of power and the quality of that power, the transmission lines need to be equipped with high-voltage power electronic circuits.

Therefore, power electronic inverters are the devices that are tasked with the responsibility of efficiently accomplishing these conversion operations. The ever-increasing need for energy on a worldwide scale has resulted in the development of innovative topologies for semiconductors and power converters that are able to deliver the total amount of power that is necessary. The race to manufacture semiconductors that are capable of withstanding higher voltage and current for the sake of more efficient systems is still very much alive and well. In addition, there has been a lot of rivalry between the use of medium voltage semiconductor devices in current converter topologies and the use of high voltage semiconductor devices in old converter topologies when it comes to power conversion.

Traditional Topologies of Multilevel Inverter

There are three primary categories of multilevel inverters, which are denoted as Neutral Point Clamped (NPC), Flying Capacitor (FC), and Cascaded H-Bridge respectively (CHB).

- **Cascaded H-Bridge Multilevel Inverter**

In 1975, Baker and Banister invented the CHB inverter, which is recognized as the first MLI to be built on semiconductors. This topology is distinguished by the presence of a series interface of single-phase H-bridge inverters. This architecture does not necessitate the use of clamping diodes or voltage capacitors in any of its circuits. The arrangement in question makes use of independent DC sources. DC sources can come from a variety of different places, including solar cells, fuel cells, and batteries. Each individual H-bridge is made up of four switches, each of which has its own diode, in addition to a separate voltage supply. The architecture of a 9-level CHBMLI is seen here in Figure 2.1.1. The output levels may be boosted by a factor of two simply by adding another individual H-bridge in cascade. The following equations provide an explanation for the highest voltage levels that the CHBMLI is capable of producing:

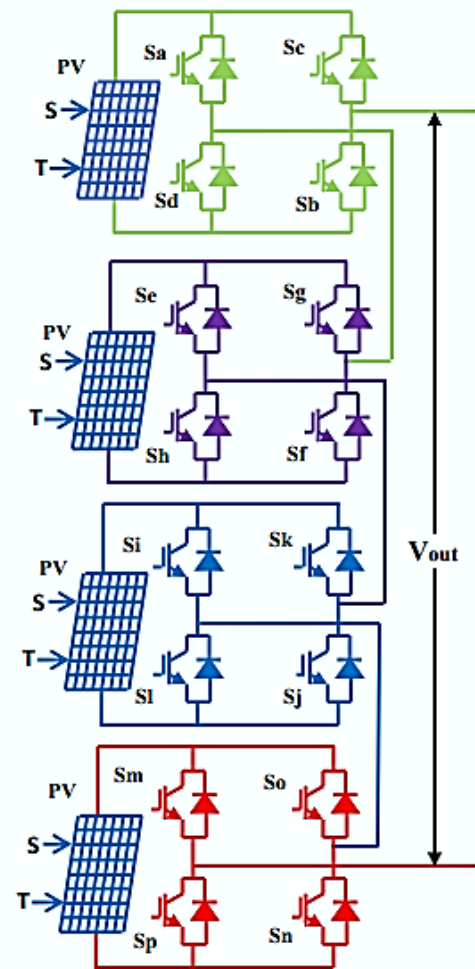

Figure 4: Circuit diagram of 9-level CHBMLI

- **Multilevel Inverter with Diode Clamped or Neutral Point Clamped**

A Neutral Point Clamped MLI (NPC) was presented for the first time. Figure 2.1.2 depicts a 9-level NPCMLI arrangement for your viewing pleasure. The NPC is a completely established arrangement that only uses one DC source. Through the use of capacitors, this DC source is split up into numerous other DC sources. The NPC is widely implemented throughout all sectors of industry, often operating at voltages ranging from 2.3 kV to 4.16 kV, with a small number of applications operating at voltages up to 6 kV. In point of fact, NPC has discovered uses for high-performance AC drives in the oil and gas sectors, as well as in the mining industry. In addition to this designation, NPC is also known as Diode Clamped Multilevel inverter (DCMLI).

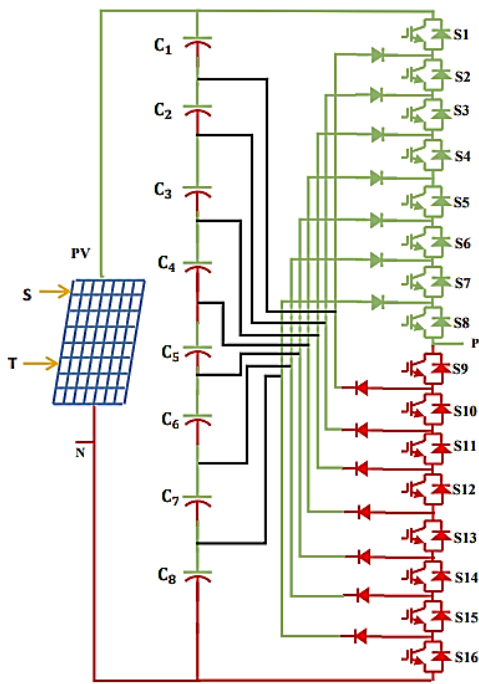

Figure 5: Neutral or Clamped Point Multilevel Inverter with Clams

STUDY AND PROJECTIONS FOR PV POWER GENERATION

Over the course of the past few decades, a significant number of researches have been devoted to addressing forecasting issues in a variety of application fields. The application of Recurrent Neural Networks, often known as RNNs, has proven to be effective in solving machine learning challenges. These models have been presented as a solution to the challenges associated with time-dependent learning. The fundamental idea behind RNNs is illustrated in Figure 3; a section of a neural network, denoted by the letter A, receives an input of the form x_t and returns a value denoted by h_t . It is important to highlight that RNNs are well adapted to learn and extract information from temporal sequences. Given an input sequence $x=(x_1, x_2, x_t)$, the following is a general formula for the RNN hidden state h t:

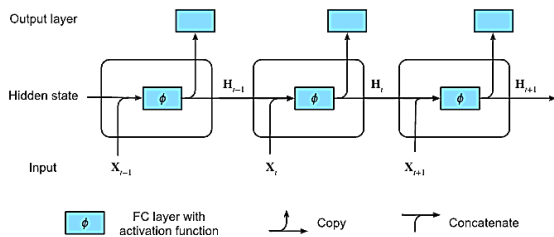

Figure 6: Basic illustration of RNN

Character-Level Language Models based on RNN

If you'll think back to our discussion of language modelling, you'll remember that our ultimate goal is to make predictions about future tokens based on the

information we already have about those tokens and the tokens that came before them (labels). Initially proposed employing a neural network to represent human language. The following is an example of a language model constructed using RNNs. Let's assume a minibatch size of 1, and that the text sequence is "machine." We tokenize text into characters rather than words and examine a character-level language model to facilitate training in later sections. In character-level language modelling, as shown in Fig. 3.1, an RNN is used to predict the next character based on the current and prior characters.

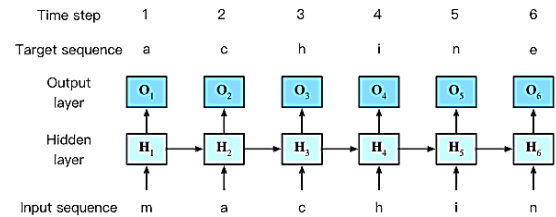

Figure 7: RNN-based Character-Level Language Models

REVIEW OF LITERATURE

A multifunctional distributed sparse (DS) control strategy was presented by Singh et al. (2020) for a solar system. The P&O approach of drawing the most power possible from PV cells is implemented in the system that has been presented. The recommended system functions as a DSTATCOM in the event that there is no PV system present.

Solar energy was recommended as the power source for an independent water pumping system by Mishra and Singh (2020). In the system that is being suggested, the water pumping is done by a Switched Reluctance Motor (SRM). The P&O method of drawing the maximum amount of electricity from PV cells is utilized in the water pumping system that has been presented.

A boost DC-DC converter was created by Jhang et al. (2020), and it is built with complementary metal-oxide-semiconductor (CMOS).

In order to reduce the initial voltage, a logic gate circuit with low leakage has been put into place.

Dehghani et al. (2020) highlighted the benefits that come with utilizing the P&O approach. Both a P&O-based controller and a fuzzy controller are put through their paces when it comes to simulating the conditions of a solar PV system that is linked to the grid. When compared to the P&O approach, the results indicate that the fuzzy controller has a performance that is somewhere in the middle. 0

Mishra and Singh (2020) presented a solar-powered water pumping system that would be incorporated into an existing grid.

For the solar photovoltaic system, the authors opted for the single step of conversion. A switching reluctance motor is what gets the job done when it comes to pumping water. The P&O approach is utilized so that the PV system may provide the greatest amount of electricity that can be harvested. The P&O approach is the most appropriate choice for tracking maximum power under any circumstances since photovoltaic (PV) systems are nonlinear by their very nature, and their performance is mostly determined by the weather conditions.

An improved leader particle swarm optimization (ELPSO) was presented by Ram et al. (2020) for the P&O approach in order to track the highest power under any unfavourable situations. The improved leader particle swarm optimization approach is used in order to locate the global maximum power point (GMPPT). When using the improved P&O approach, one may achieve findings that are both more accurate and comprehensive.

A drift free P&O approach was presented by Mishra et al. (2020) for the stand alone wind energy conversion system. The traditional P&O approach generates oscillations and is unable to accurately track the MPP throughout a broad range of wind speeds. The wind data is being gathered with the help of the speed sensor, and it will be sent to the suggested P&O technique so that correct power can be extracted.

THE IMPORTANCE OF MACHINE LEARNING METHODS IN PV PANEL DEFECT DETECTION

Systems trained using machine learning (ML) can analyse data and identify patterns with minimal human oversight. The production, efficiency, and quality of PV panels are all influenced by their surroundings and can thus be predicted. Improved forecasting techniques can assist energy providers and consumers get the most out of these installations. Even while renewables offer lower operating costs over the long term, the initial investment in equipment is typically rather substantial figure 5. If the user is able to accurately predict when the grid will be compromised, they will be able to take preventative measures and save a significant amount of money.

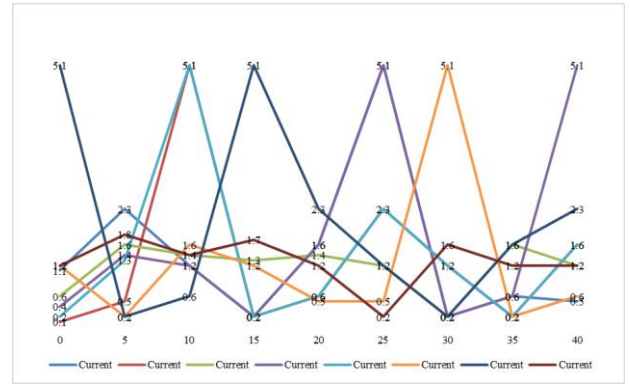

Figure 8: Machine Learning Techniques in Fault Diagnosis

One of the more fruitful uses of machine learning to far has been in the field of predictive analytics. Machine learning algorithms are applied to the data collected from the equipment's operation to predict when maintenance is required. By following this procedure, technicians can avoid performing unnecessary maintenance and costly failures. Human inspectors can try to perform the same tasks without any assistance, but they typically fail. One study found that predictive maintenance aided by AI was up to 25.3% more effective and 24.6% more precise than manual maintenance.

An Explanation of the Diverse Sensors Employed in PV Panels for the Detection of Faults

The suggested approach requires both electrical and environmental data to be collected when the PV panel is in operation. This is necessary in order to achieve the feasible outcomes. The numerous approaches that have been put into practice by a variety of researchers are the single most important factor in determining whether or not the PV system is able to successfully detect faults figure 5.1. The passive component of the diagnostic, also known as fault detection, requires that a normal threshold and a failure threshold be identified and then fitted.

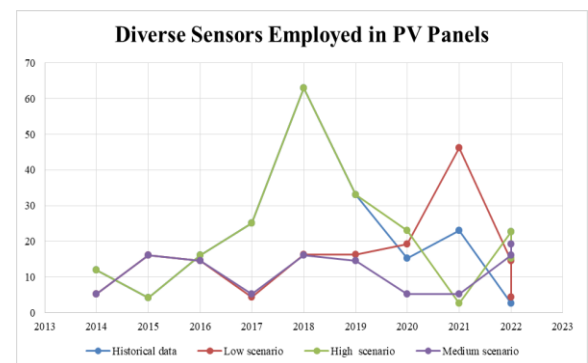

Figure 9: Diverse Sensors Employed in PV Panels

The diagnostics procedure that was based on the model was used to create each residue value that

was displayed here. The non-active component of the diagnostic data was monitored separately with the immediate power output by the PV system. The fundamental concept behind techniques for flaw identification is that, for a large solar system, it is necessary to subject the entire string to a wide variety of irradiance and temperature ranges. It is possible to view the resultant string current, which is caused by a combination of the types of faults and the locations of the defective modules in the string.

The Benefits Obtained from the Detection of Defects in PV Panels

Permanent power losses can be classified as defects in solar panels; however, a more fine-grained analysis may be applicable if there are failure specific patterns that can be exploited. The identification of the problem leads to an increase in the effectiveness of the solar panels. Performance is the metric that is used to evaluate the capacity of a solar panel to transform the sun's rays into usable energy.

At the point when the sun gleams on two sun powered chargers with various evaluations for a similar timeframe, the board with the higher rating will deliver a more noteworthy measure of energy than the board with the lower rating. The productivity of sunlight based not entirely settled by how much power that is delivered by photovoltaic cells.

The proficiency of a sunlight based charger is impacted by the organization of the cells, the electric game plan of the parts, and different factors. It is crucial to have solar panels with a top-tier efficiency if you want to get the most out of your energy usage and reduce your bills. Contrasting two sunlight based chargers, one of which has an effectiveness rating of 21% while different has a productivity rating of 14%, the board with the higher rating will deliver 50% more kilowatt-hours (kWh) of force under similar circumstances.

CONCLUSION

This paper compiles and discusses a number of previously published articles that cover recent developments and research in the following areas: I different potential blames that can happen in PV board; (ii) on the web/distant oversight of PV boards; (iii) job of AI procedures in shortcoming finding of PV boards; (iv) different sensors utilized for various issue recognitions in PV boards; and (v) advantages of shortcoming recognizable proof in PV boards. These points are separated into five classes: I different According to the viewpoint of issue classification, various other possible wellsprings of flaws, including halfway concealing issue, hamper, and open circuit shortcoming, as well as deficiencies in diodes (both hindering and sidestep diodes), were analyzed in more prominent profundity. In this paper, we examined the different internet based procedures that are intended to screen the mistakes that happen in PV boards in light of the sort of sensor that is utilized and the observing of the PV boards.

These web-based strategies screen the mistakes that happen in PV boards in view of the observing of the PV boards. The proposed LSTM-based method to momentary determining of photovoltaic sun oriented power yield has created results that are very uplifting. Later on, we intend to carry out and test the exhibition of other RNN models like the Gated repetitive unit (GRU) model and to consolidate extra data, for example, meteorological information to additionally work on the exactness of our gauges. This will be important for our endeavours to additional improve the nature of our figures.

A conversation on the plan, activity, and upkeep of planetary groups has been given. According to an analysis that was conducted, the most significant breakthroughs in photovoltaic systems are now being made in the areas of better designs of photovoltaic systems, as well as optimal operation and maintenance; these are the primary foci of PV systems research.

REFERENCES

1. Antonanzas J, Osorio N, Escobar R, Urraca R, Martinez-de Pison F, Antonanzas-Torres F. Review of photovoltaic power forecasting. *Solar Energy*. 2016;136:78-111
2. Behera MK, Majumder I, Nayak N. Solar photovoltaic power forecasting using optimized modified extreme learning machine technique. *Engineering Science and Technology, an International Journal*. 2018;21(3):428-438
3. Chen, Z.; Wu, L.; Cheng, S.; Lin, P.; Wu, Y.; Lin, W. Intelligent fault diagnosis of photovoltaic arrays based on optimized kernel extreme learning machine and IV characteristics. *Appl. Energy* 2017, 204, 912–931.
4. Dhimish, M.; Holmes, V.; Dales, M. Parallel fault detection algorithm for grid-connected photovoltaic plants. *Renew. Energy* 2017, 113, 94–111.
5. Duman, S.; Li, J.; Wu, L.; Yorukeren, N. Symbiotic organisms search algorithm-based security-constrained AC–DC OPF regarding uncertainty of wind, PV and PEV systems. *Soft Comput.* 2021, 25, 9389–9426.
6. Eseye AT, Zhang J, Zheng D. Short-term photovoltaic solar power forecasting using a hybrid wavelet-PSO-SVM model based on SCADA and meteorological information. *Renewable Energy*. 2018;118:357-367
7. Harrou F, Dairi A, Taghezouit B, Sun Y. An unsupervised monitoring procedure for detecting anomalies in photovoltaic systems using a one-class support vector machine. *Solar Energy*. 2019;179:48-58
8. Harrou F, Taghezouit B, Sun Y. Improved kNN-based monitoring schemes for detecting faults in PV systems. *IEEE Journal of Photovoltaics*. 2019;9(3):811-821

9. Harrou F, Taghezouit B, Sun Y. Robust and flexible strategy for fault detection in grid-connected photovoltaic systems. *Energy Conversion and Management*. 2019;180:1153-1166
10. Izgi, E.; Öztopal, A.; Yerli, B.; Kaymak, M.K.; Sahin, A.D. Short–mid-term solar power prediction by using artificial neural networks. *Sol. Energy* 2012, 86, 725–733.
11. Ji, D.; Zhang, C.; Lv, M.; Ma, Y.; Guan, N. Photovoltaic array fault detection by automatic reconfiguration. *Energies* 2017, 10, 699.
12. Qing X, Niu Y. Hourly day-ahead solar irradiance prediction using weather forecasts by LSTM. *Energy*. 2018;148:461-468
13. Sobri S, Koochi-Kamali S, Rahim NA. Solar photovoltaic generation forecasting methods: A review. *Energy Conversion and Management*.
14. Srivastava S, Lessmann S. A comparative study of LSTM neural networks in forecasting day-ahead global horizontal irradiance with satellite data. *Solar Energy*. 2018;162:232-247.
15. Ventura, C.; Tina, G.M. Development of models for on-line diagnostic and energy assessment analysis of PV power plants: The study case of 1 MW Sicilian PV plant. *Energy Proc.* 2015, 83, 248–257.
16. Wang H, Yi H, Peng J, Wang G, Liu Y, Jiang H, et al. Deterministic and probabilistic forecasting of photovoltaic power based on deep convolutional neural network. *Energy Conversion and Management*. 2017;153:409-422
17. Wang K, Qi X, Liu H. A comparison of day-ahead photovoltaic power forecasting models based on deep learning neural network. *Applied Energy*. 2019;251:113315
18. Wu, J.; Yan, S.; Xie, L. Reliability analysis method of a solar array by using fault tree analysis and fuzzy reasoning Petri net. *Act. Astronaut.* 2011, 69, 960–968.
19. Ziar, H.; Manganiello, P.; Isabella, O.; Zeman, M. Photovoltatronics: Intelligent PV-based devices for energy and information applications. *Energy Environ. Sci.* 2021, 14, 106–126.

Corresponding Author

Kirti Pathak*

Research Scholar, University of Technology, Jaipur,
Rajasthan