

A Review on the Division of Autonomic Modulation in the Cognitive Radio

Harshit Panchal*

Department of Electrical Engineering, SS College of Engineering, Rajasthan Technical University, Kota, India

Abstract – Cognitive Radios have become a key research area in communications over the past few years. They play an important role in dynamic spectrum management and interference identification. Automatic Modulation Classification is the automatic recognition of the modulation format of a sensed signal. Most modulated signals exhibit the property of Cyclostationary that can be exploited for the purpose of classification. A feature-based method called Cyclostationary Feature Detection is able to classify different modulation schemes. The Spectral Correlation Function obtained from the sensed signal is used as a cyclic feature. The Cycle frequency Domain Profile derived from Spectral Correlation Function is used as a discriminator in the classification process since several modulation schemes have unique cycle frequency domain profiles. The neural network approach based on the learning mechanism is employed for pattern matching. It is used for classification of data patterns and distinguishing them into predefined set of classes. The two layered neural network is trained using the Back Propagation Algorithm.

Index Terms— AMC, Blind Equalizer, Cyclostationary, Cognitive Radios.

-----X-----

GENERAL OVERVIEW

Modulation is the process of varying a periodic waveform in order to use that signal to convey a message. The purpose of AMC algorithms in a radio receiver is to identify the existence of a signal in a particular frequency band at a given location at a given time and then determine the modulation type being employed in the spectrum. For the receiver, AMC is the intermediate step between signal detection and demodulation. AMC plays an important role in dynamic spectrum management and interference identification for civilian, commercial and military applications. Cognitive Radios have become a key research area in communications over the past few years. They play an important role in dynamic spectrum management and interference identification. Automatic Modulation Classification is the automatic recognition of the modulation format of a sensed signal. Most modulated signals exhibit the property of Cyclostationary that can be exploited for the purpose of classification. A feature-based method called Cyclostationary Feature Detection is able to classify different modulation schemes. The Spectral Correlation Function obtained from the sensed signal is used as a cyclic feature. The Cycle frequency Domain Profile derived from Spectral Correlation Function is used as a discriminator in the classification process since several modulation schemes have unique cycle frequency domain profiles. The neural network approach based on the learning mechanism is employed for pattern

matching. It is used for classification of data patterns and distinguishing them into predefined set of classes. The two layered neural network is trained using the Back Propagation Algorithm.

Cognitive Radio (CR), basically introduced by Mitola [7], has become a key research area in the field of communications. CR is a hopeful technology that is capable of achieving better spectrum utilization by opportunistically finding and utilizing vacancy frequency bands [1]. AMC, as the name suggests is the automatic recognition of modulated signals present in a particular band of frequency. AMC is an important component of cognitive radio that improves spectral efficiency by modifying transmission and reception according to the spectral environment. CRs are basically intended to form an ad-hoc network known as a Cognitive Radio Network (CRN) [3], which has potential military and commercial applications. In public safety and military applications, the CRs must be capable of performing fixed and on-the move communications between highly different elements in a harsh environment which may also be susceptible to jamming attacks and malicious interference [4]. For the secure and reliable operation of a CRN, CRs must be able to identify all users in the frequency band simultaneously. Feature based AMCs [5] are widely used because of easy implementation and better performance. The multiuser AMC using fourth order cumulant based approach is recently proposed in [6]. By

using multiple antennas at the receiver the CR can identify the number of transmitting users which is generally not possible while using a single antenna receiver.

When the channel information is not known, choosing the initial parameters of the equalizer becomes a difficult task. In this project a unified framework for cognitive radios as shown in Fig.1.1 is proposed. The order of the blind equalizer is adjusted based on the probability of classification of the AMC.

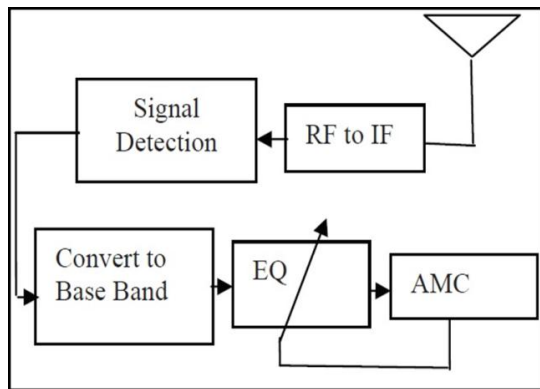

Fig. 1. Block Diagram for the Proposed Method

The main contribution among many automatic modulation classification algorithms is based on cyclostationary feature detection method. This feature extracting algorithm can be used with classifier such as Neural Network. Signal detection and signal classification based on pattern matching algorithm becomes robust using cyclostationary of signals. Neural networks are helpful for modulation classification when i) the carrier signal and bandwidth are unknown and ii) the interfering signals and noise are in considerably effective[8].

COGNITIVE RADIO

Due to the Speedy expansion of wireless applications in recent years, spectrum assets are facing massive demands. The radio spectrum is a limited resource, regulated by government agencies such as the Federal Communications Commission (FCC) in the United States. Within the current spectrum regulatory structure, many parts of the spectrum are entirely allocated to specific services and no violation from unlicensed users is legitimate. The spectrum scarcity problem is getting less of a problem due to the appearance of new wireless services. Luckily, the doubts about spectrum scarcity are being shattered by a recent review made by a Spectrum Policy Task Force (SPTF) within the FCC undertaken in New York City, reporting that the maximum total spectrum occupancy is only 13.1% from 30 MHz to 3 GHz. The electrifying results shed light on the problem of spectrum scarcity and inspired a new direction of possible solutions.

Why Cognitive Radio:

Cognitive radio is emerging as a promising software defined radio technology in wireless communication for maximizing the use of limited resources of radio bandwidth. This software defined radio technology adapts the dynamic radio environment to maximize the utilization of the limited radio recourses .There are some reasons behind this technology which are mentioned below:-

- ▶ Today's radio systems are not aware of their radio spectrum environment and operate in a specific frequency band.
- ▶ In some locations or at some times of the day, 70 percent of the allocated spectrum may be sitting idle.
- ▶ New bandwidth-intensive wireless services are being offered.
- ▶ Unlicensed users constrained to a few overloaded bands.
- ▶ Increasing number of users.

This growth requires more spectral bandwidth to satisfy the user's demand. The key feature of this technology is awareness of the radio environment. A good and clear definition of cognitive radio can be found in Simon Haykin's words "Cognitive radio is an intelligent wireless communication system that is sensitive of its neighbouring environment (i.e., outside world), and uses the methodology of understanding-by-building to learn from the environment and adapt its internal states to statistical variations in the incoming RF stimuli by making corresponding changes in certain operating parameters in real-time, with two primary objectives in mind.

- ▶ Exceedingly trustworthy communication whenever and wherever needed;
- ▶ Efficient utilization of the radio spectrum

Smartness of cognitive radio technology can be illustrated in the cognitive cycle shown in figure 3.1.

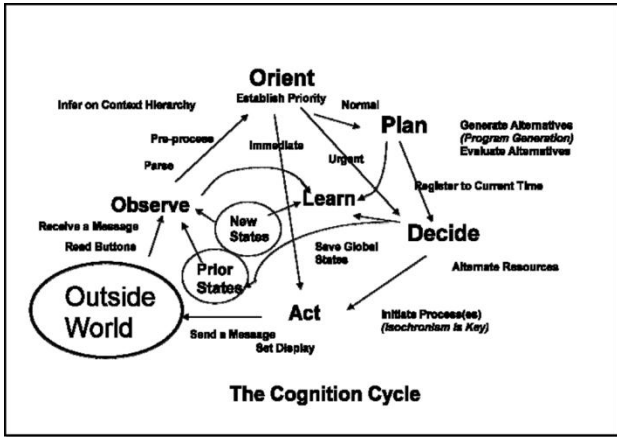

Fig 1.1- Cognition Cycle showing the smartness of this technology

Vacant Frequency Bands (Spectrum holes)

Most of today’s radio systems are not aware of their radio spectrum environment and operate in a specific frequency band using a specific spectrum access system. Investigations of spectrum utilization indicate that not all of the spectrum is used in space (geographic location) or time. A radio, therefore, that can sense and understand its local radio spectrum environment, to identify temporarily vacant spectrum and use it, has the potential to provide higher bandwidth services, increase spectrum efficiency and minimize the need for centralized spectrum management. This could be achieved by a radio that can make autonomous (and rapid) decisions about how it accesses the spectrum. Cognitive radios have the potential to do this. Cognitive radios have the potential to jump in and out of unused spectrum gaps to increase spectrum efficiency and provide wideband services.

We can define spectrum holes as:-

“A spectrum hole is a band of frequencies assigned to a primary user, but, at a particular time and specific geographic location, the band is not being utilized by that user.” [1]

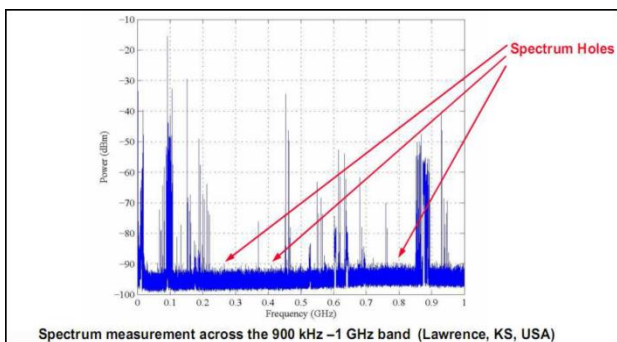

(a)

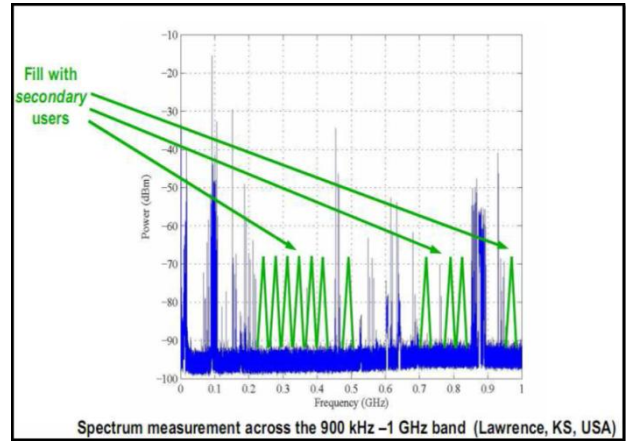

Figure-2: Spectrum Measurement across the 900 kHz-1 GHz (Lawrence, KS, USA) (a) Frequency holes (b) Fill those holes with secondary user’s data

Problem Identification

Open Problems in AMC

Research in AMC assumes either SISO or SIMO channels, that is, they assume only a single transmitting user. However, in a CR scenario, this is not the case. In some applications, CR must be able to classify signals transmitted by legal users and malicious users at the same time. Therefore, an AMC that can classify signals from multiple users simultaneously is needed for CR. Thus, one of the objectives of the dissertation is to develop AMC for a multiuser system. Another open problem is that most of the AMC algorithms in the literature assume the channel to be Additive White Gaussian Noise (AWGN) and do not consider multipath.

Multipath not only affects the performance of receiver symbol detection but also affects the performance of the AMC. The second objective of this dissertation is to develop AMC that is robust to multipath channels.

Open Problems in Blind SISO Channel Equalization and Estimation

As mentioned earlier, adaptive blind equalization typically adapts the equalizer parameter by minimizing some special cost functions. For non-blind equalization, due to the availability of a training sequence, the most widely used cost function is the mean square error (MSE). Because of the lack of a training sequence, blind equalization algorithms use cost functions that implicitly utilize the HOS of the received signal. These cost functions are generally nonlinear and have many local minima. The convergence of these algorithms highly depends on the initial setting of the equalizer. Since the cost function is non-MSE, good symbol detection performance is not always guaranteed. Due to the convergence of

the algorithm to a local minimum, not only symbol detection performance is affected, but the performance of the AMC, which is an integral part of the CR, is also affected. Robust blind equalizers can be designed if the performance of the AMC is also considered while adapting equalizer parameters.

One of the open problems is to design a robust blind equalizer that enhances both the performance of the AMC and symbol detection. This can be achieved by formulating a cost function that also incorporates the performance of the AMC. This cost function will differ for different kinds of feature based AMC's.

The parameters of the blind equalizer are then adapted so that this new cost function is minimized. Thus, some of the main objectives of the dissertation with respect to SISO blind equalization are to:-

- ▶ Design new blind equalizer architectures that can improve the performance of both symbol detection and AMC.
- ▶ Formulate cost functions that are related to the performance of some of the widely-used feature based AMC's.
- ▶ Develop algorithms that adapt the parameters of the new equalizer such that the cost function is maximized.

BLIND EQUALIZATION

Overview

Equalization is a very essential topic in data communication. Due to the communication channel, which can be wire line or wireless and furthermore time variant, the transmitted data symbols are distorted linearly over the channel. However, to overcome the effects of the channel, one can employ an equalizer which is adapted during the transmission of a training sequence. If transmission of training is not possible or not available, other ways have to be found to improve system performance. If the communication signals belong to a finite alphabet, signal properties are exploited to find an equalizer without transmission of training data. Generally, a cost function is defined which is iteratively minimized and an optimal solution is found. Other methods which try to estimate Higher Order Statistics of the signals and according to these estimates an inverse are computed. This paper shows a short overview about blind equalization strategies and tries to sketch a few basic ideas when designing algorithms for blind equalization.

Generally, a communication channel can be represented by a filter as depicted in Fig. 1. The transmitted data symbols {s[k]} belong to a finite alphabet A, which can be defined as $A = \{+1, -1\}$, $\{1 + j, 1 - j, -1 + j, -1 - j\}$, . . . typically visualized in a

constellation diagram. The receiver has no information about the propagation channel h(t) which is in our further discussions assumed to be linear and time invariant. However, in wireless communications the mobile radio propagation channel will have time variant behavior [1], [6] but is still linear. The output signal of the channel x(t) may be additionally disturbed by noise w(t) which is assumed to be i.i.d. Gaussian.

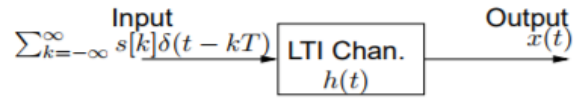

Fig 3- Communication scenario

Considering the model for the communication channel, the objectives for the equalizer $G(z, \theta)$ are easily formulated. The combined channel and equalizer response in discrete-time domain should be just a scaled and delayed version of an ideal delta pulse,

$$\text{i.e., } h[k] = a\delta[k - \Delta]. \quad (1)$$

This is often referred to as the distortion-less channel. Assuming the channel is known, analytic expressions for ZF and MMSE equalizers are easily given as [1]

$$G_{zf}(z, \theta) = \frac{z^{-\Delta}}{H(z)} \quad (2)$$

and

$$G_{mmse}(z, \theta) = \frac{H^*(z)z^{-\Delta}}{H(z)H^*(z^{-1}) + S_w(f)}, \quad (3)$$

Where $H(z)$ represents the z-transform of the channel impulse response and $S_w(f)$ is the Power Spectral Density (PSD) of the noise process, respectively.

BLIND EQUALIZATION

Since there is no training for parameter estimation available in blind equalization the used algorithms have to exploit signal properties. One specific property of linear systems is that the output PSD relates to the input PSD by

$$S_x(\omega) = S_s(\omega)|H(e^{j\omega})|^2 + S_w(\omega), \quad (4)$$

Where $S_s(\omega)$ is the PSD of the source symbols s[k]. It is seen in (4) that a second order statistics measure as the PSD contains just magnitude information about the frequency response of the channel. Phase information is not available in this case and higher order moments/cumulants or spectra have to be considered when phase

equalization has to be performed. One possible example is the to use Higher Order Statistics (HOS) to obtain the trispectrum of the output as:-

$$T_x(\omega_1, \omega_2, \omega_3) = T_s(\omega_1, \omega_2, \omega_3)H(e^{j\omega_1})H(e^{j\omega_2}) \times H(e^{j\omega_3})H(e^{-j(\omega_1+\omega_2+\omega_3)}) + T_w(\omega_1, \omega_2, \omega_3) \quad (5)$$

Where for i.i.d. input signals $s[k]$ and Gaussian noise $w[k]$ the trispectra are constant, i.e.,

$$T_s(\omega_1, \omega_2, \omega_3) = \gamma_s, \quad T_w(\omega_1, \omega_2, \omega_3) = 0 \quad (6)$$

And the phase can be obtained as

$$\angle T_x(\omega_1, \omega_2, \omega_3) = \angle H(e^{j\omega_1}) + \angle H(e^{j\omega_2}) + \angle H(e^{j\omega_3}) - \angle H(e^{-j(\omega_1+\omega_2+\omega_3)}) + \angle \gamma_s. \quad (7)$$

As mentioned already, second order statistics (SOS) only provide magnitude information of the channel and all SOS methods are insufficient for blind equalization of a mixed phase channel containing zeros inside and outside the unit circle. Furthermore, it is not possible to identify a mixed phase channel from it's outputs if the input is i.i.d. Gaussian since only second order statistics are available [7]. Although the exact inverse of a non minimum phase channel is unstable, a truncated anticausal expansion can be delayed by Δ to allow causal FIR approximation of a ZF equalizer. As a further fact, ZF equalizers cannot be implemented for channels $H(z)$ with zeros on the unit circle. Any FIR approximation will have unbounded approximation error.

Objectives of Research

The main goal of this work is to identify the type of modulation in an independent manner with the use of plug and play module. As, some of the applications of SDR involve military and relief operation (non-cooperative relay environments), wireless data is sent using a suitable modulation technique to provide guaranteed Quality of Services such as bounded packet delay and low packet loss rate. The constraints like limited available frequency bandwidth, time-varying multipath fading, shadowing, thermal noise and mobility are also considered in this work.

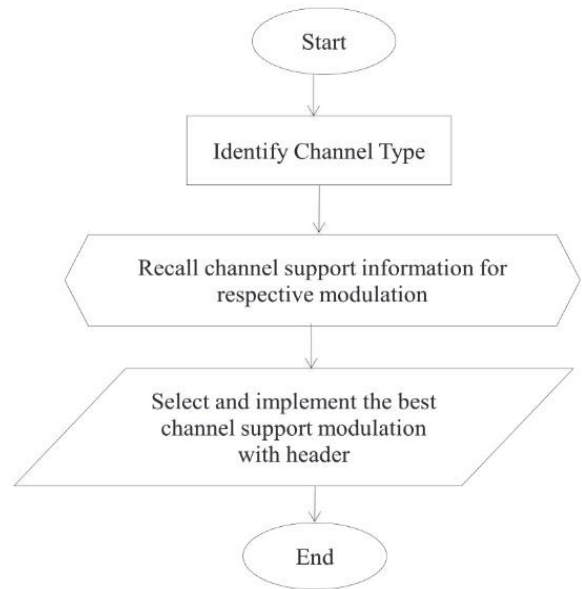

Fig. 4 Flowchart Depicting the Objectives of this Research

Efficient techniques to overcome these limitations involves adaptively changing the modulation mode based on the channel quality information sensed by the receiver and fed back to the transmitters to the throttling of the window size by the sender depending on the receiver advertised window in TCP protocol. This is analogy Therefore; the receiver should identify the type of modulation the transmitter has sent (Refer Fig.4).

To achieve the goal of this research, the following objectives are set:

- ▶ Auto scanning range of IP address to detect node in different communication schemes such as synchronous, asynchronous and slotted time communication.
- ▶ Transmit data from the node using shortest path algorithm for dynamic routing.
- ▶ To perform modulation identification technique using pilot sequence.
- ▶ To validate the modulation identification technique using Slot Tracking.
- ▶ To have scheduler based implementation and based on the priority of anode, the availability of the modulation scheme is utilized.
- ▶ To investigate the cluster maintenance in the presence of mobility.
- ▶ To implement Automatic Modulation Identification using hardware for SDR.

- To ensure secure data transmission using Hamming Encoding technique.

Proposed Method

The proposed receiver structure is shown in Fig.1. This kind of receiver structure is highly suitable for cognitive radio (CR). When a CR is turned on, it has to scan a large band of the spectrum to locate, recognize and use a signal. The purpose of AMC is to determine what single or multiple modulation types are being employed in the received signal. The reason for using cyclostationary based AMC is because of its good performance at low SNR. Also CDP used in this AMC can be used to extract important information like, keying rate, pulse shape etc. The performance of this AMC is affected in the presence of a multipath channel (Demonstrated in simulation section). In order to overcome this disadvantage a blind equalizer used before AMC. The equalizer not improves the performance of the AMC but also eliminates Inter symbol interference (ISI). The predictor based equalizer discussed in previous section is chosen because it can be used for non-constant modulus signals, and has good convergence property.

CR's often operate in a non-stationary environment and hence the channel information is not known. It is necessary to initialize the parameters of the equalizer such as: length of the filter, initial coefficients and learning rate. In the proposed system, the performance of the AMC is used as a measure to initialize the parameters of the equalizer. In this concept is illustrated by just adjusting a single parameter called length of the equalizer.

Algorithm for adjusting equalizer length

In general, all fading channels are modelled as time varying FIR filters and hence the length of the above equalizer, i.e. N1, plays an important role. When the receiver has no information about the channel then choosing the length of the equalizer (N1) is difficult. In this paper, we choose the value of N1 based on the probability of classification of the AMC. A simple algorithm to choose the value of N1 is shown below

Step 1: Choose a small initial length for the equalizer, i.e. N1=2.

Step 2: find the probability of classification for the AMC (P_a).

Step 3: increase the number of tap in the equalizer if $P_a < P_{th}$.

Step 4: again, find and there is no need of updating if $P_a > P_{th}$ or else repeat step 2.

For determining P_a the following method is used. Let K be the number of samples required for the AMC to decide. The AMC algorithm is applied to $N * K$ input samples i.e. AMC makes N decisions. Let N_i be the number of times the i^{th} modulation scheme is detected. Then P_i , the probability of classification for the i^{th} modulation scheme is given by

$$P_i = \frac{N_i}{N}$$

P_a , the probability of classification for the AMC is defined as

$$P_a = \max(P_1, \dots, P_L)$$

MODELLING AND SIMULATION

Blind Equalization

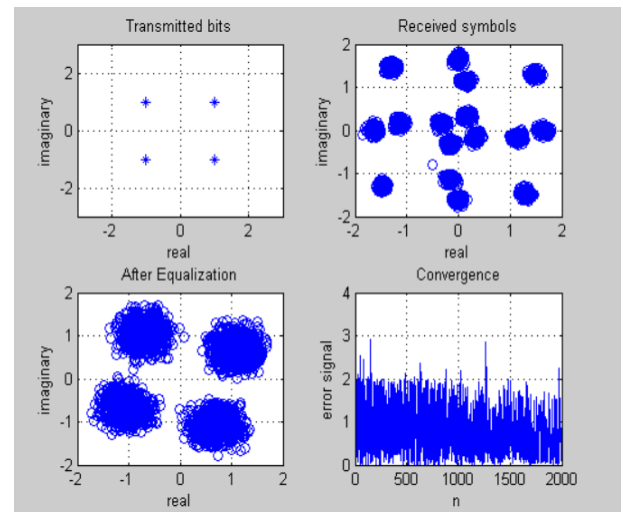

Fig. 5 Performance through Blind equalization

Blind equalizers are used for recovering the transmitted input sequence using only the output signal with no knowledge of the channel. Constant Modulus Algorithm (CMA) is one of the earliest blind equalization algorithms, but involves a nonlinear optimization technique [3], and also cannot be applied to a modulation scheme that does not have a constant modulus property like higher order QAM. We simulated Blind equalization technique in MATLAB to check this method's performance. So that, we can use it in Cognitive radio. We used cyclostationary function & SCF (spectrum correlation function) algorithm in our programme and created blind equalizer based on that. As shown in the convergence part of the figure we get the output signal from blind equalizer having some error, that's when we will implement Adaptive rate control or Adaptive modulation

control. In the equalization phase we get appropriate amount of data too.

CONCLUSION

The proposed MIMO blind equalizer was tested under different scenarios. From the simulation results it can be seen the MIMO blind equalizer improves the performance of both multiuser AMC and multiuser symbol detection with Genetic algorithm. Irrespective of the kind of channel and the type of feature used, it can be seen from the simulation results that we get 15% improvement at higher SNR's and at least 10% improvement in performance at 0dB SNR. The performance of proposed equalizer was analysed using computer simulations and yielded promising results. The simulation results showed that the combination of the SCF algorithm with the trained neural network performs accurately. The CDP can be used as a good discriminator of modulation schemes, because of the uniqueness in their CDP patterns. Using this cyclo stationary based AMC algorithm, signal modulation types can be determined quickly and reliably. The results show very good recognition since overall accuracy of all confusion matrix is 99%. The proposed system performs exceptionally well even at low SNR levels. Automatic Modulation Classification not only gives the assurance of the presence of signal by detecting its scheme of modulation but also helps to demodulate the signal by knowing its type. Performance of this cyclic spectrum based AMC system is tested in a stationary noise environment such as AWGN channel. Performance degradation of the cyclo stationarity based AMC in the presence of a multipath channel was shown. A unified predictor based blind equalizer and AMC was proposed which overcomes this disadvantage. The effect of the length of the equalizer on the performance of AMC was demonstrated based on which a simple algorithm to update the length of the equalizer was proposed.

REFERENCES

1. S. Haykin (2005). "Cognitive radio: Brain-empowered wireless communications," IEEE J. Select. Areas Commun., vol. 23, pp. 201-220.
2. J. Polson (2004). "Cognitive radio applications in software defined radio," in Proc of the SDR Forum Conference 2004.
3. S. Haykin (2000). Unsupervised adaptive filtering, Vol. II: Blind Deconvolution, John Wiley & Sons, Inc.
4. M. S. Radenkovic, and T. Bose (2005). "Convergence analysis of a predictor based adaptive Equalizer for IIR channels," International J. Signal Proc., Vol. 2, No. 2.
5. M. S. Radenkovic, and T. Bose (2006). "A Blind Adaptive Equalizer for Single-Input Multiple-Output IIR Channels with common zeros," ISCAS 2006.
6. A. Fehske, J. Gaeddert and J. H. Reed (2005). "A new approach to signal classification using spectral correlation and neural networks," in Proc. IEEE Dynamic Spectrum Access Nets., pp. 144-150.
7. K. Kim, I. A. Akbar, K. K. Bae, J. Um, C. M. Spooner, and J. H. Reed (2007). "Cyclostationary approaches to signal detection and classification in cognitive radios," in Proc. IEEE Dynamic Spectrum Access Nets., pp. 212-215.

Corresponding Author

Harshit Panchal*

Department of Electrical Engineering, SS College of Engineering, Rajasthan Technical University, Kota, India