

Matlab Simulation of Solar PV & Concentrating Solar Power Plant (Csp) As a Renewable Energy Sources

Mukesh Sharma*

Department of Electrical Engineering, SS College of Engineering, Rajasthan Technical University, Kota, India

Abstract – This paper presents the importance of concentrating solar power plant compare to other renewable energy sources like solar PV cells, wind power generation, ocean thermal energy etc. we discuss the basic concept an introduction of concentrating solar power plant their working and types of components used for concentrating the solar energy. Day by day the use of solar energy is increased all over world, so it is necessary to study about solar energy. Still to date solar PV cells type solar power plant used in solar energy but due to their lower efficiency (near about 14%-18%) use of concentrating solar plant is come into picture. In our paper we will discuss about its demand and advantages compared to other solar PV cells. In this paper we will design the solar thermal power plant into the matlab-simulink and SAM (System Advisor Model) software. We are comparing the PV cell type solar power plant to CSP plant using the results of matlab-simuink design.

-----X-----

I. INTRODUCTION

The time has come where the earth's energy situation can be defined as critical, which might be one of the reasons why many countries are becoming more conscious on subjects related to energy consume, energy efficiency, climate change, investment in renewable energies, dependence on fossil fuels...

Therefore the uses of renewable energy sources are increased. The different kinds of renewable sources which are generally used in modern times are given as below:-

1. Solar power plant
2. Hydro power plant
3. Geothermal energy
4. Wind energy
5. Biomass etc.

These different renewable energy sources have their own Advantages and disadvantages. But in the latest time use of solar energy is increased due to its feasibility, simple operation, etc. Compare to other sources. So, use of solar energy is popular in worldwide.

“The solar rays come onto the earth surface is possible to convert into electrical energy then it provides electrical energy to world for 25 years.”

Concentrating Solar Power (CSP) plants use mirrors to concentrate sunlight onto a receiver, which collects and transfers the solar energy to a heat transfer fluid that can be used to supply heat for end-use applications or to generate electricity through conventional steam turbines. Large CSP plants can be equipped with a heat storage system to allow for heat supply or electricity generation at night or when the sky is cloudy. There are four CSP plant variants, namely:

1. **Parabolic Trough,**
2. **Fresnel Reflector,**
3. **Solar Tower**
4. **Solar Dish,**

Which differ depending on the design, configuration of mirrors and receivers, heat transfer fluid used and whether or not heat storage is involved? The first three types are used mostly for power plants in centralised electricity generation, with the parabolic trough system being the most commercially mature technology. Solar dishes are more suitable for distributed generation.

II. ROLE OF SOLAR ENERGY IN RENEWABLE ENERGY SOURCES

Solar energy is a highly renowned alternative energy type. The intensity of the sun's irradiation that reaches the globe yearly is equivalent to 92 billion tons of petroleum. A calculation from 2002 states that the energy received from the sun in one hour was greater than the world used in one year.

◆ Solar PV System:-

Solar PV systems employ solar cells made from semiconductor materials. Direct or scattered sunlight incident on these materials causes a certain portion of it to be absorbed within the cells. The energy of the photons absorbed knock electrons loose from their atoms which can then travel through an external circuit by means of metal contacts attached to the solar cells. Owing to electric fields inherent within the cells, the electrons flow in one direction thereby producing direct current (DC) electricity. A single solar cell produces only a small amount of power for which they are interconnected to form panels or modules that give 50 to 200 watts [1]. These PV modules are combined with a set of additional application dependent system components to form a PV system. Fig. 1 illustrates those components that make up the PV system.

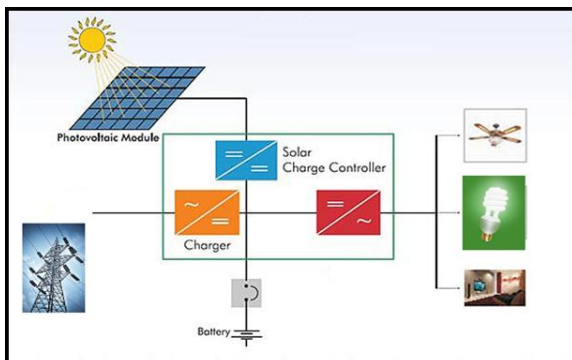

Fig. 1.1 Solar PV system [1]

The electricity produced by the PV modules is stored in batteries for later use when there is no sun. Deep-cycle batteries are used that provide electricity over long periods of time and can repeatedly charge and discharge up to 80% of their capacity. Charge controllers regulate the rate of flow of electricity from the modules to the battery or the loads or to both simultaneously. It keeps the battery from overcharging or overloading thus prolonging its life [1].

◆ Concentrating Solar Power (CSP) Plant:-

In concentrating solar power (CSP) technology sun's Direct Normal Irradiation (DNI) is concentrated to produce heat of temperature 400°C to 1,000°C [1]. This heat is used to produce electricity by

conventional steam cycle, or combined cycle, or Stirling engine.

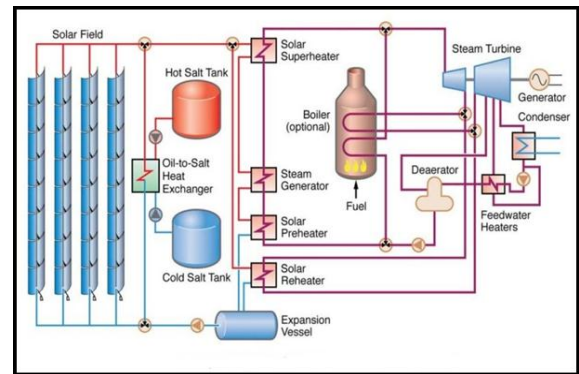

Fig 1.2-Components of CSP with TES (Thermal Energy Storage)

III. TYPES OF CSP PLANT

Based on the process of collecting and concentrating solar radiation, the CSP can be categorized into four major technologies:-

- i) Parabolic Trough,
- ii) Solar Tower or Central Receiver,
- iii) Parabolic Dish and
- iv) Linear Fresnel Reflector (LFR).

1) Parabolic Trough: - This technology uses parabolic trough shaped mirrors to concentrate the incident DNI onto a receiver tube which is placed at the focal line of the trough. The basic elements of parabolic trough power station are:-

- a) Solar collector field,
- b) Conventional electricity generating unit (steam Rankine cycle or combined Cycle) and
- c) Thermal storage (optional) [1].



Figure-2: CSP Parabolic Trough Solar Collectors [1]

PT is the most mature CSP technology, accounting for more than 90% of the currently installed CSP capacity. As illustrated in Figure 2, it is based on parabolic mirrors that concentrate the sun's rays on heat receivers (i.e. steel tubes) placed on the focal line. Receivers have a special coating to maximise energy absorption and minimise infrared re-irradiation and work in an evacuated glass envelope to avoid convection heat losses. The solar heat is removed by a heat transfer fluid (e.g. synthetic oil, molten salt) flowing in the receiver tube and transferred to a steam generator to produce the super-heated steam that runs the turbine. The use of molten salt at 550°C for either heat transfer or storage purposes is under demonstration. High temperature molten salt may increase both plant efficiency (e.g. 15%-17%) and thermal storage capacity [1].

IV. MODELLING AND SIMULATION OF PV AND CSP

◆ **Modelling and Results of Solar-PV System**

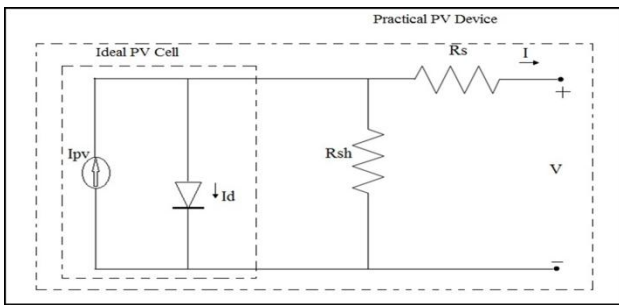

Fig-3.1: Equivalent circuit of a practical PV device [6]

The output current can be measured by subtracting the diode currents and current through resistance from the light generated current. From this circuit, the output current of the cell is expressed as,

$$I = I_{pv} - I_d - I_{Rsh} \tag{1}$$

$$I = I_{pv} - I_0 \left[\exp\left(\frac{V+IR_s}{a}\right) - 1 \right] - \left(\frac{V+IR_s}{R_p}\right) \tag{2}$$

Where, $a = \frac{NS.A.K.Tc}{q} = Ns. A. V_T$

MATLAB MODEL AND RESULTS:-

A 30 KW solar-PV array is realized considering 24,080 cells (344x70 dimensions) using equation-(1)-(2). A Matlab model for the same is developed.

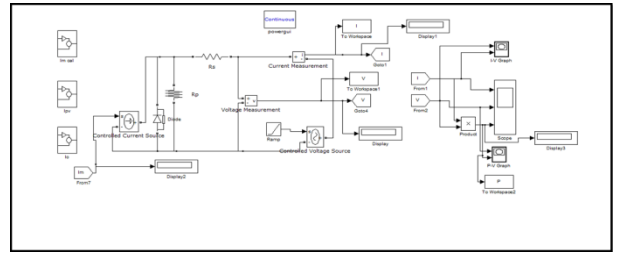

Fig 3.2: Simulink model of a PV device

After the simulation, we obtained the following results,

Simulation Results of solar panel-

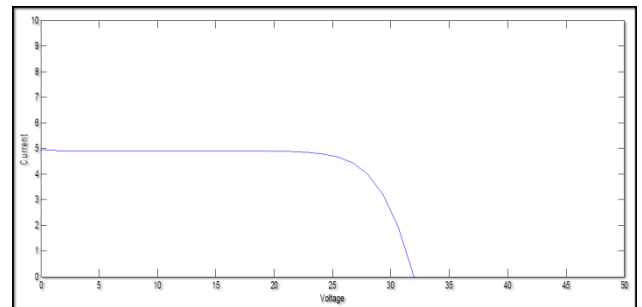

Fig 3.3-I-V Characteristic

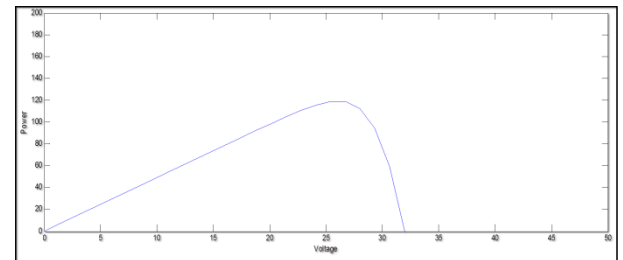

Fig 3.4-P-V Characteristic

Modelling and Results of CSP Plant:-

For building this model Matlab tool called Simulink is used, being the general view of this model presented in Figure 3.5.

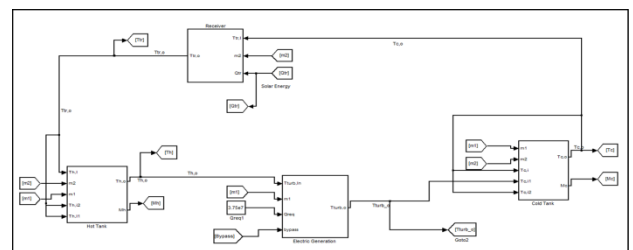

Fig 4.1- Simulink model of the CSP plant with storage system

Initially two equal mass flows are defined and they are assumed to be constant values, namely m1 and m2. The mass flow m1 is the molten salts flow rate that goes out of the hot tank and passes

through the steam generator for providing the steam in order to produce electrical power in the turbine and then continues flowing to the cold tank from the steam generator. The mass flow m_2 is the molten salts flow rate that goes out of the cold tank into the tower receiver for warming up and then continues towards the hot tank. In order to design the heat transfer fluid mass flow, equation (1) is developed as a function of \dot{Q} , considering the maximum energy at the tower receiver for obtaining this values, which means that mass is flowing at its maximum flow rate (variable mass flows are not considered on this model), as shown in equation (2):-

$$Q_{tr} = m C_p \Delta T \leftrightarrow m = Q_{tr} \div C_p * \Delta T \dots \dots \dots (1)$$

The dimensions of the storage tanks determine the autonomy of the CSP plant (to remark the importance of this fact) and the masses that control the cold and the hot tank are defined by M_c and M_h , respectively. It is admitted that each tank has the same dimensions, with 8 meters of diameter (d) and 4 meters of height (h tank) in a cylindrical shape. Therefore, the volume of each tank is calculated following equation (2):-

$$V_{tank} = \pi * r^2 * h \dots \dots \dots (2)$$

In **Figure 4.1** is presented the detailed model of the tower receiver subsystem which provides the modelling based in this equation and is working with a block called switch that works as a condition "if" for defining when the mass flow m_2 is different from zero or is zero, i.e. when this mass flow is zero means that the outlet temperature of the tower receiver ($T_{tr,o}$) is equal to the inlet temperature of the tower receiver ($T_{tr,i}$).

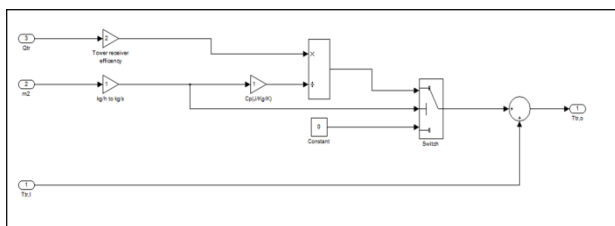

Fig 4.2 Receiver subsystem for outlet temperature modelling

These equations applied to the hot tank modelling are defined with another subsystem in Simulink (**Figure 4.2**) which represents the math operations for obtaining $T_{h,o}$ and $T_{h,o+}$. What is made initially is defining a $T_{h,ini}$ when the mass of the tank is zero and then the initial temperature is considered at the first hour, otherwise is taken the previous value of $T_{h,o}$ and then a next iteration will progress continuously in the next hour.

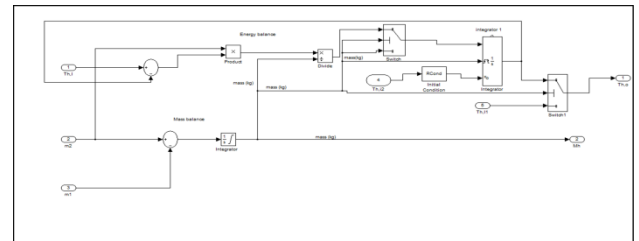

Fig 4.3- Hot tank subsystem designed with Simulink

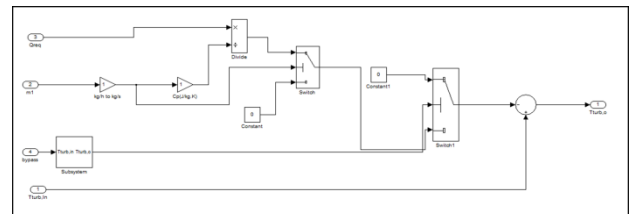

Fig 4.4-Electric generation subsystem designed with Simulink

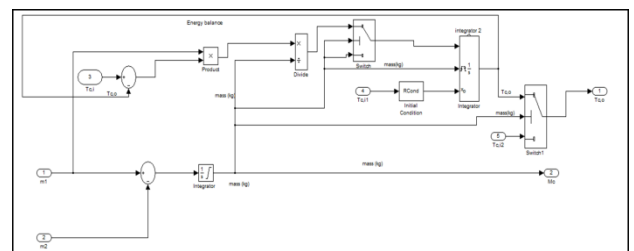

Fig 4.5-Cold tank subsystem designed with Simulink

Results:-

The SAM 2.0 model results of CSP plant is shown in fig below:-

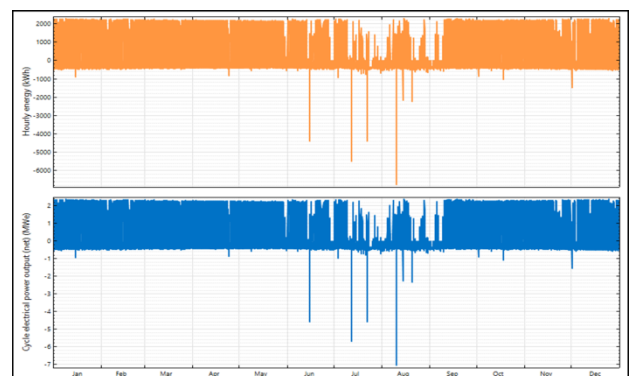

Fig 4.6- Hourly energy and Inlet & cycle net electrical power

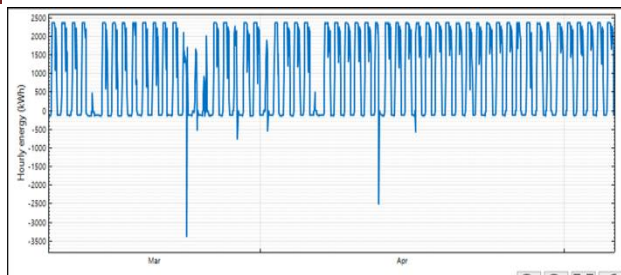

Fig 4.7-Hourly Energy

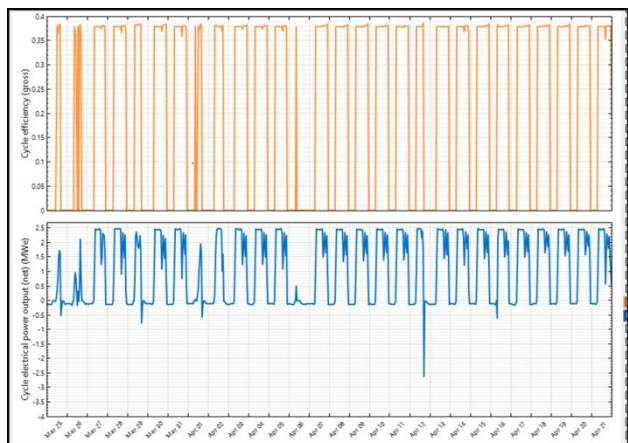

Fig 4.8-Cycle Efficiency and Net Electrical power output

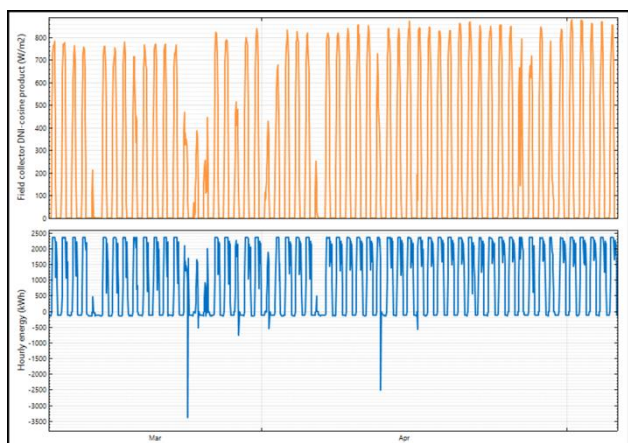

Fig 4.9-DNI and Hourly Energy

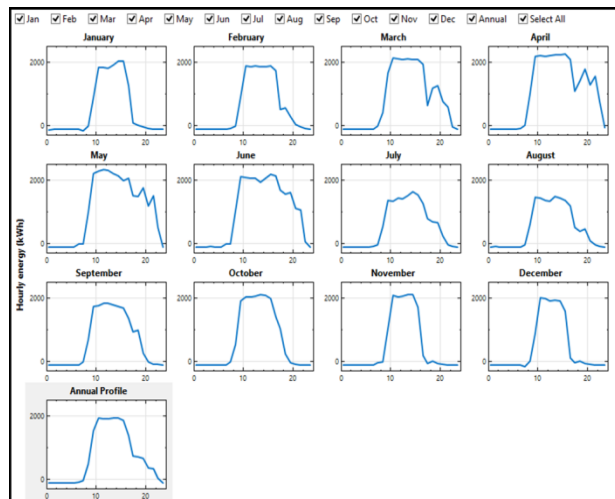

Fig 4.10- Every Month Energy

CONCLUSION:

In this paper detail description for designing of Solar PV plant and parabolic trough solar power plants with thermal storage was developed. The methodology is based on the individual design of different components and subsequent integration of the components into the whole system. CSP technology tells that the best of those technology is the possibility to accumulate heat for the electricity production, allowing its use even when the sun is not shining, during cloudy periods or night times when it has a storage system. There are two kinds of solar power plant: - PV and CSP. CSP has so many advantages over PV type solar power plant.

REFERENCES

1. Nafisa Noor, Sadid Muneer : "Concentrating Solar Power (CSP) and Its Prospect in Bangladesh".
2. Tahsin Faraz Control and Applications Research Group (CARG) Department of EEE, BRAC University, Dhaka, Bangladesh "Benefits of Concentrating Solar Power over Solar Photovoltaic for Power Generation in Bangladesh".
3. Spiru PARASCHIV, Simona Lizica paraschiv, ion v. Ion, nicușor vatachi "Design and sizing characteristics of a solar thermal power plant with cylindrical parabolic concentrators in dobrogea region".
4. O. H. Abdalla, Senior Member, IEEE, R. Al-Badwawi, Senior Member, IEEE, H. Al-Hadi, H. Al-Riyami, Member, IEEE, and A. Al-Nadabi, Member, IEEE NO.5, Oct. 1980.
5. Keith E. Holbert, Senior Member, IEEE, Colin J. Haverkamp "Impact of Solar

Thermal Power Plants on Water Resources and Electricity Costs in the Southwest”.

6. Mihir K. Patel, Prof. Alpesh M. Patel, Prof. Bhupendra K. Patel “analysis of concentrating solar power plant in renewable energy sources”.
7. R. Guédeza, J. Spellinga, B. Laumerta, T. Franssona, “Optimization of Thermal Energy storage integration strategies for Peak power production by Concentrating solar power plants”.
8. Lewis M. Fraa, James E. Avery, Takashi Nakamura JX Crystals, Issaquah, WA Physical Sciences Inc, San Ramon, CA “electricity from concentrated Solar IR in solar lighting applications”.
9. Z. Ma, G.C. Glatzmaier, and M. Mehos “Development of solid particle Thermal energy storage for concentrating solar power plants that use fluidized Bed technology”.
10. Thermal Power Plants on Water Resources and Electricity Costs in the Southwest”.
11. Ibrahim Patel Member IEEE, S. Alekhya, D. Aarti, Raghavender Kulkarni “Sensible heat storage for power generation”.
12. Dustin F. Howard, Jiaqi Liang, Ronald G. Harley “Control of Receiver Temperature and Shaft Speed in Dish-Stirling Solar Power Plants to Meet Grid Integration Requirements”.
13. E. H. Camm, Member, IEEE, S. E. Williams, Member, IEEE “Solar Power Plant Design and Interconnection”.
14. R Wilson and J Prange “concentrated solar power: what a South African Company has learned from designing, building and commercializing A Linear Fresnel concentrated solar thermal power (csp) Plant”.

Corresponding Author

Mukesh Sharma*

Department of Electrical Engineering, SS College of Engineering, Rajasthan Technical University, Kota, India