

Development of Android Application for Automated Water Irrigation System and Crop Suggestion Based on Analysis of Data

Shubham Ganesh Bangale^{1*} Nityanand Madhukar Gore², Omkar Rajkumar Muthawat³

^{1,2,3} Department of Computer Engineering, JSPM's Imperial College of Engineering and Research, Pune, India

Abstract – Today the biggest contributor to the GDP in India is Agriculture Sector. So there is need to improve the facilities provided to the farmers to increase the crop production. There are some Problems in farming which cannot be solved by the farmer such as Exact water required by the land, nutrients available in soil. Whereas we can overcome these problems by using embedded system which consist of Raspberry Pi, Arudino Uno, DHT 11 Temperature sensor, moisture sensor. So using this devices we can build a system which can sense the data or parameters from the soil then that data is analysed with the help of Raspberry Pi and ultimately provide crop suggestion and also used in automatic water irrigation. This system also includes Android interface with simple understandable form.

Keywords: Irrigation, Agriculture, Nutrients, Automation.

-----X-----

I. INTRODUCTION

Now a days in India as well as all over the world we are facing the problem of less water and global warming also the lack of knowledge in the technical field is also a problem. With the help of technology many problems related to farm can be overcome. Today many farmers carryout the irrigation on the basis of prediction which is not accurate it might be 60-70% accurate, but by using the proposed system the prediction will be accurate up to 90%.

II. COMPONENTS

Here is some component details which is used to complete this project. All this components are embedded system components which is work in real time environment.

A. Raspberry pi:

Raspberry pi is important component in this project for develop an own cloud for data storing purpose. Raspberry pi stores and analyse data which is sensed by sensors and provide particular output to the user on Android app.

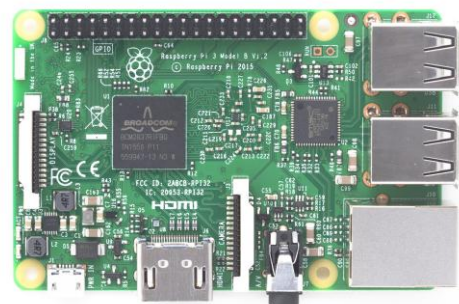

Fig. 1: Raspberry pi

B. Arduino uno:

Arduino uno is the microcontroller which is use to interaction purpose between sensor and raspberry pi, also Arduino uno is useful for doing communication between raspberry pi and Android app.



Fig. 2: Arduino uno



Fig. 5: Water irrigation pump

C. Moisture sensor:

This is the sensor component which is use to sense moisture in soil and send digital value to the Arduino uno for data analysis purpose.

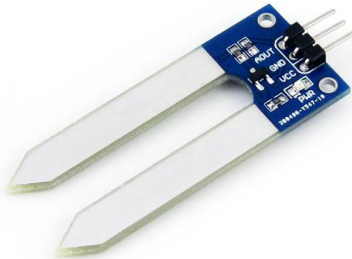

Fig. 3: Moisture sensor

D. DHT 11/ Temperature sensor:

DHT 11 is sensor which is sense temperature value from the surrounding environment for analysis purpose after sense digital value sent to the arduinouno.



Fig. 4: Temperature sensor

E. Irrigation Pump:

Irrigation pump is use to check the motor can start and stop as per condition.

III. PROPOSED MODEL

Basically there are many advantages of using newer technology in our case the advantages are efficient use of water and providing suggestion of crops which are to be sowed next. Raspberry pi is a microprocessor which does the processing on the sensed data by the sensors and gives the output (crop suggestion).

Sensing is done by Hygrometer and DHT 11 sensors. The data provided by the sensors is real-time and more accurate than human. Here accuracy is important as we want to prevent the loss of water by using only exact amount of water required. Surrounding temperature values are required to check the suitable environment required by the particular crop.

Using cloud i.e. raspbian cloud we provide remotely accessible data to user on the android device. For this purpose we develop an android app to access the data from the cloud which is sensed by the sensors and analysed by Raspberry Pi. Raspberry Pi does processing on the data and gives the output in the form of actual water required and crop suggestion on the android app after the calculation.

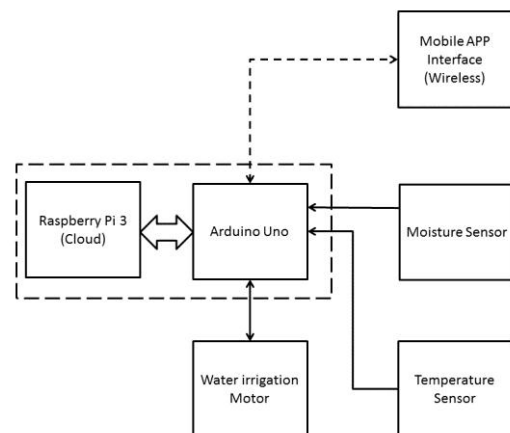

Fig. 6: Block diagram of system

Raspberry pi in the system which is used in this project as a server to store data value which is sensed by sensors and analyse that data to crop suggestion. Arduino uno is microcontroller in this project is use to control sensor and connect to android interface and also start and stop motor as per moisture value. Water irrigation motor is use to show irrigation system in this project model. Temperature sensor and Moisture sensor is use to sense data from soil and environment and send that value to the Arduino uno. Android is the interface which is use to display the all output related sensed data and analysed data and also crop suggestion.

IV. RESULT

We use Temperature sensor to calculate temperature and Moisture sensor to sense moisture level it provides accurate readings of the surrounding environment.

Result is displayed as follows:

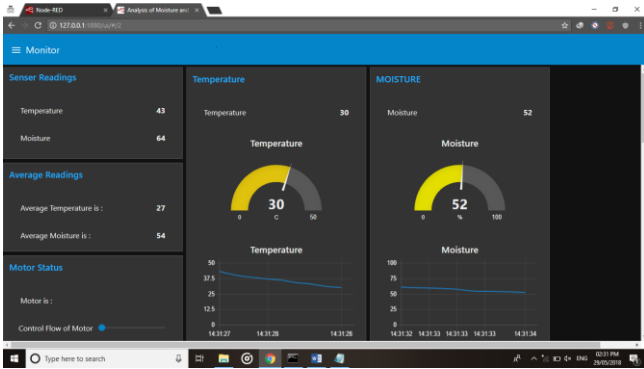

Based on the average readings and previous year crop, the crop suggestion is provided.

Suggestion is provided as follows:

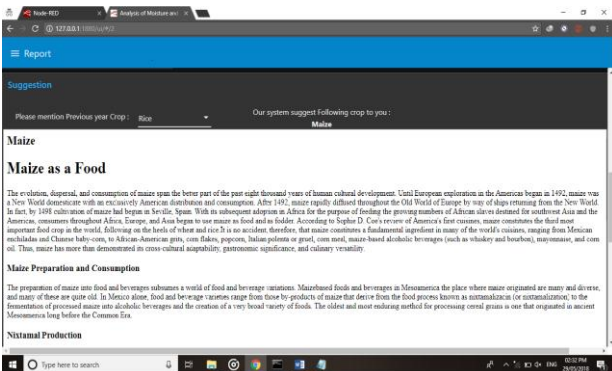

The Sensor values are stored in following manner:-



To display actual water requirement and crop suggestion to user we use android web browser interface. The Web browser retrieve data from cloud i.e. Raspberry Pi and display it to user and based on that give suggestion about crop which is to be sowed next and the required amount of water also is displayed on android Web browser.

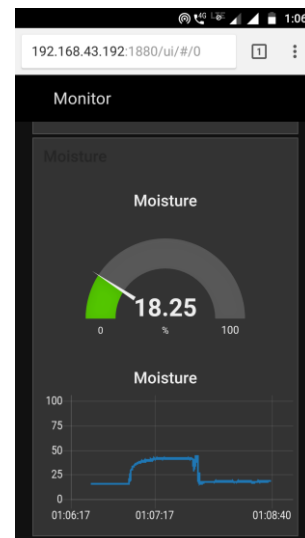
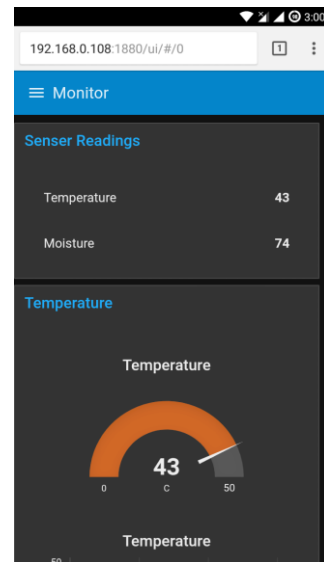

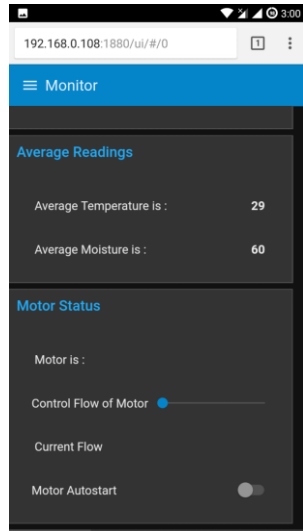

V. CONCLUSION

This system help farmers to manage the available water efficiently and also get suggestion about crops which is suitable for the surroundings with more accuracy. For this system the hardware required is available at low cost. By use of the android app it is easy for users to interact with the system. This system can also be implemented in warehouses by increasing some sensors and also hardware. This system provide worldwide accessing of sensor data over the network. This system is in the budget of 70-80% of farmers in India. So in this way the system proves to be a money as well water saver after actual implementation.

REFERENCES

- Ahmed Imteaj, Tanveer Rahman, Muhammad Kamrul Hossain and Saika Zaman (2016). "IoT based Autonomous Percipient Irrigation System using Raspberry Pi." December 18-20, 2016.
- Chandan Kumar Sahu, Pramitee Behera (2015). "A Low Cost Smart Irrigation Control System." IEEE SPONSORED (ICECS 2015).
- Jaydeep Rusia, Shubhankar Majumdar, Alok Naugarhiya, Bibhudendra Acharya (2016). "Remote Temperature & Humidity Sensing Through ASK Modulation Technique." 978-1-5090-5515-9/16 IEEE@2016.
- K. K. Namala, Krishna Kanth Prabhu A. V., Anushree Math, Ashwini Kumari, Supraja Kulkarni (2016). "Smart Irrigation with Embedded System." IEEE Bombay Section Symposium (IBSS) 2016.
- Matti Satish Kumar, T. Ritesh Chandra, D. Pradeep Kumar and Dr. M. Sabarimalai Manikandan (2016). "Monitoring moisture of soil using low cost homemade Soil Moisture Sensor and Arduino UNO." Jan. 22 & 23, 2016, Coimbatore, INDIA.

Md. Asaduzzaman Miah, Mir Hussain Kabir, Md. Siddiqur Rahman Tanveer and M. A. H. Akhand (2015). "Continuous Heart Rate and Body Temperature Monitoring System using Arduino UNO and Android Device.", 978-1-4673-9257-0/15 (EICT 2015).

Nikhil Agrawal, Smita Singhal (2015). "Smart Drip Irrigation System using Raspberry pi and Arduino." ISBN: 978-1-4799-8890-7/15 (ICCCA2015).

Padma Nyoman Crisnapati, I. Nyoman Kusuma Wardana, I. Komang Agus Ady Aryanto, Agus Hermawan (2017). "Hommons: Hydroponic Management and Monitoring System for an IOT Based NFT Farm Using Web Technology." IEEE 2017.

Pandurang H. Tarange, Rajan G. Mevekari, Prashant A. Shinde (2015). "Web based Automatic Irrigation System using wireless sensor network and Embedded Linux board." [ICCPCT] 2015.

Parth Kuchroo, Jaspreet Singh, Ekambir Sidhu (2016). "Autonomous Dynamic Thermoelectric Energy Harvesting system for water heating purposes." 978-1-5090-2080-5/16 (IIIT), Pune.

Sakshi Sharma, RashmiVashisth. "Zigbee Based Centralised Patient Monitoring System." International Conference on Computational Intelligence and Communication Networks 2015.

Sanket Salvi, Pramod Jain S.A., Sanjay H.A., Harshita T.K., M. Farhana, Naveen Jain, Suhas M. V. (2017). "Cloud Based Data Analysis and Monitoring of Smart Multi-level Irrigation System Using IoT." 978-1-5090-3243-3/17 (I-SMAC 2017).

Suraj Nandkishor Kothawade, Shaikh Mohammed Furkhan, Abdul Raof and Kunjan Suresh Mhaske (2016). "Efficient Water Management for Greenland using Soil Moisture Sensor."(ICPEICES-2016).

Yanping Wang, Zongtao Chi (2016). "System of Wireless Temperature and Humidity Monitoring Based on Arduino Uno platform." Sixth International Conference on Instrumentation & Measurement 2016.

Corresponding Author

Shubham Ganesh Bangale*

Department of Computer Engineering, JSPM's
Imperial College of Engineering and Research, Pune,
India

E-Mail – shubhambangale8196@gmail.com