

# Design and Analysis of Crankshaft Using Topology Optimization in ANSYS

Mukund Hingne<sup>1</sup> Dr. Rashmi Dwivedi<sup>2\*</sup>

<sup>1</sup> M.Tech Scholar, Department of Mechanical Engineering, Sagar Institute of Science and technology, Bhopal

<sup>2</sup> Associate Professor, Department of Mechanical Engineering, Sagar Institute of Science and Technology Bhopal

**Abstract – The crankshaft is an important component of an engine. Crankshaft is one of the critical components for the effective and precise working of the internal combustion engine. A crankshaft can be called as the heart of any I.C. engine since it is the first recipient of the power generated by the engine. Its main function is to convert the oscillating motion of the connecting rod into rotary motion of the flywheel. The main function of a camshaft is to convert rotary motion of the crankshaft into vertically reciprocating motion of the valves required to open and close the intake and exhaust valves of engine cylinders, with the assistance of cams located on it and an intermediate mechanism. This paper presents the design connecting rod of internal combustion engine using the topology optimization. This paper 1 basic model and 3 implement model is proposed. The crankshaft model 3D geometry is created by using CATIA V5 and then it is import in ANSYS 19.0. and check all the result in three different load case 22624N, 32624N and 42624N.**

**Keywords: ANSYS, crankshaft, CATIA V5, Forget steel, Topology optimization, weight reduction**

-----X-----

## 1. INTRODUCTION

The crankshaft is a moving part of the internal combustion engine (ICE). It's main function is to transform the linear motion of the piston into rotational motion. The pistons are connected to the crankshaft through the connecting rods. The crankshaft is mounted within the engine block. The crankshaft is fitted into the engine block through its main journals. The connecting rods are fixed on the conrod journals of the crankshaft. On opposite sides of the conrod journals the crankshaft has counterweights which compensates outer moments, minimizes internal moments and thus reduces vibration amplitudes and bearing stresses (Reddy, et. al., 2017).

In the present work, one crank throw model was used to calculate the static strength of crankshaft. Software based analysis techniques use multi-body simulation tools for accurately predicting the operating loads acting on the engine components. The 3D model of crankshaft system, obtained from CATIA V5 software is analyzed in Ansys Software to assess the motion and loads acting on the crankshaft.



Fig.1 Crankshaft (Patil, et. al., 2017)

For the design optimization process of crankshaft further topology optimization technique of Ansys is used to remove the unnecessary material from the crank shaft.

## 2. TOPOLOGY OPTIMIZATION IN ANSYS

Unless it has been topologically optimized, every part in an assembly probably weighs more than it needs to. Extra weight means excess materials are being used, loads on moving parts are higher than necessary, energy efficiency is being compromised and shipping the part costs more. Now, with Topology Optimization technology, ANSYS Mechanical gives you the tools you need to design

durable, lightweight components for any application. You can define objectives easily and apply controls to ensure that manufacturing requirements are met, minimum material thicknesses are set and exclusion areas are defined (Pandiyan, et. al., 2016).

Topology optimization in ANSYS Mechanical allows you to:

- Take into account multiple static loads combined with optimizing for natural frequencies (modal analysis)
- Satisfy requirements for minimum material thickness
- Observe rules around feature direction (for machining operations for example)
- Have scope for both cyclic and planar symmetry
- Easily validate results

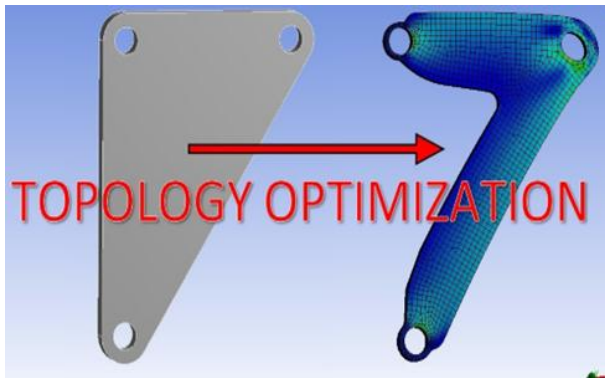

Fig.2 Topology Optimization

### 3. METHODOLOGY

#### 3.1 Modelling

In this modelling section 1 basic model and 3 implement model is proposed. The crankshaft model 3D geometry is created by using CATIA V5 and then it is import in ANSYS 19.0. and check all the result in three different load case 22624N, 32624N and 42624N.

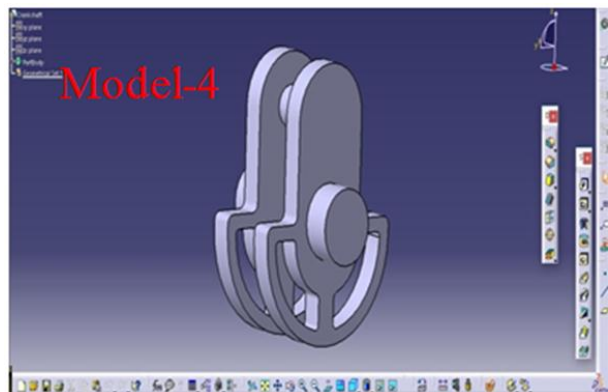
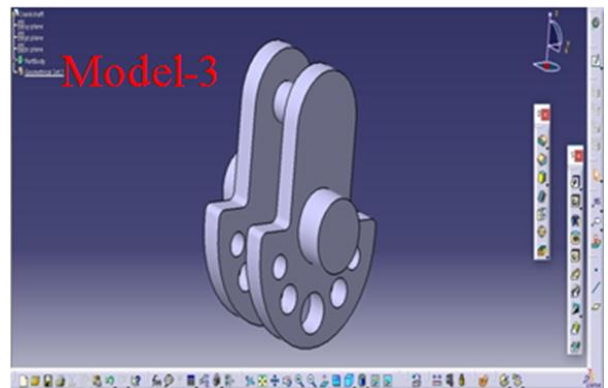
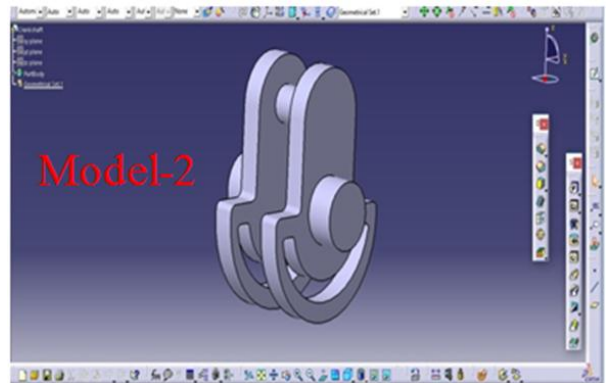
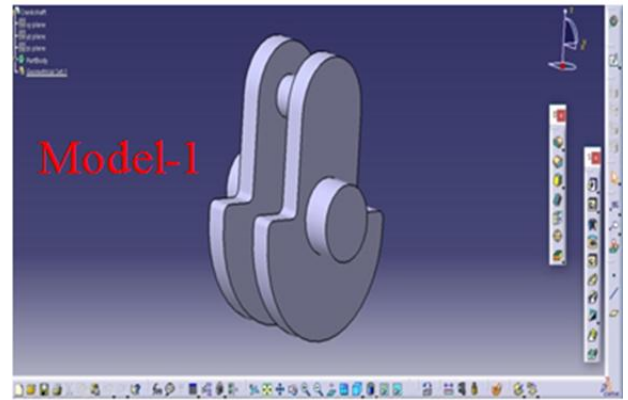

Fig.3 Different Crankshaft Model

### 3.2 Material property

The forget steel is used to above analysis the mechanical property are used in ANSYS are shown in table below:

**Table 1. Material Property**

Material	Forget steel
Density (Kg/m3)	7833
Young's Modulus (MPa)	2.21E+05
Poisson's Ratio	0.3

### 3.3 Meshing

After applying meshing 26641 nodes and 19234 elements is generated in crankshaft.

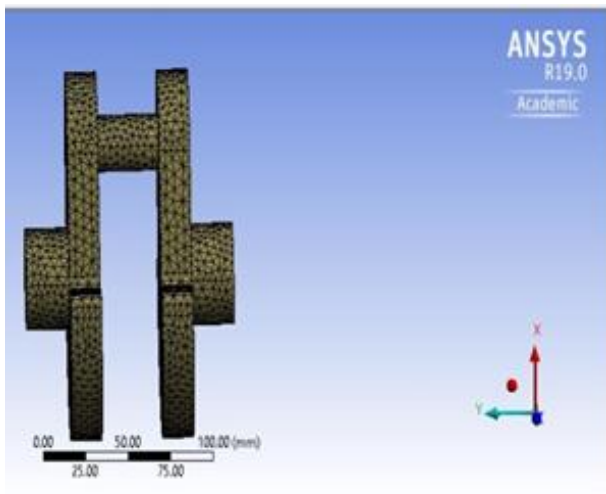
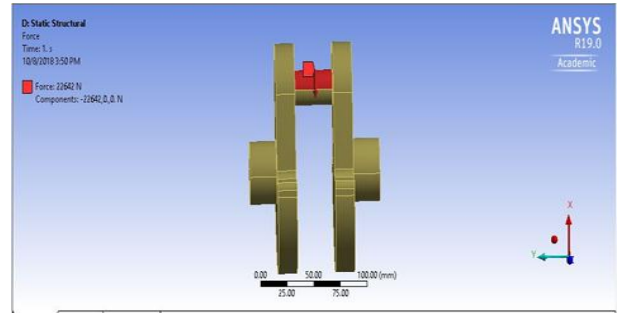

**Fig.4 meshing of crankshaft**

### 3.4 Boundary condition

The FE model created was subjected to static structural analysis after assigning suitable material properties and boundary conditions.

The force acting on the crankpin for case-1 due to gas loads at 4500 rpm. The maximum force acting on the crankpin is 22624 N.



**Fig.5 Applying force**

The force acting on the crankpin for case-2 due to gas loads at 4500 rpm. The maximum force acting on the crankpin is 32624 N.

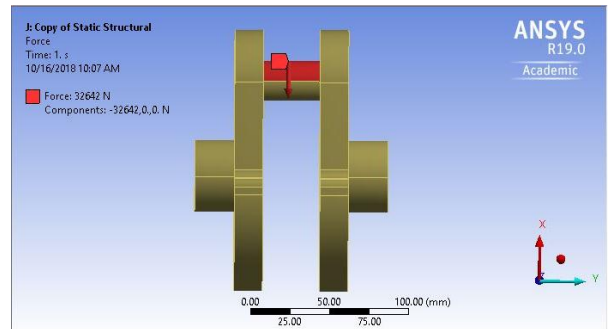

**Fig.6 Applying force**

The force acting on the crankpin for case-3 due to gas loads at 4500 rpm. The maximum force acting on the crankpin is 42624 N.

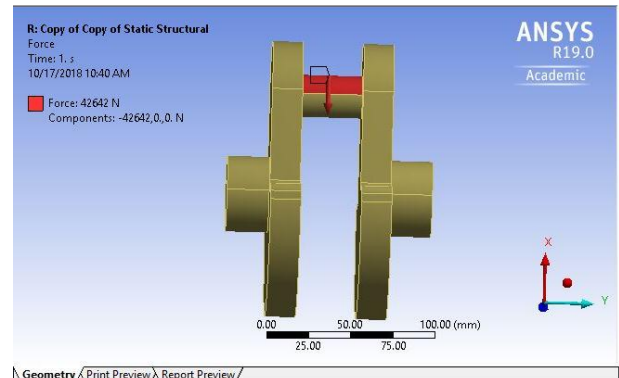

**Fig.7 Applying force**

### 3.5 Fixed support

The crankshaft is fixed in both the end of shaft.

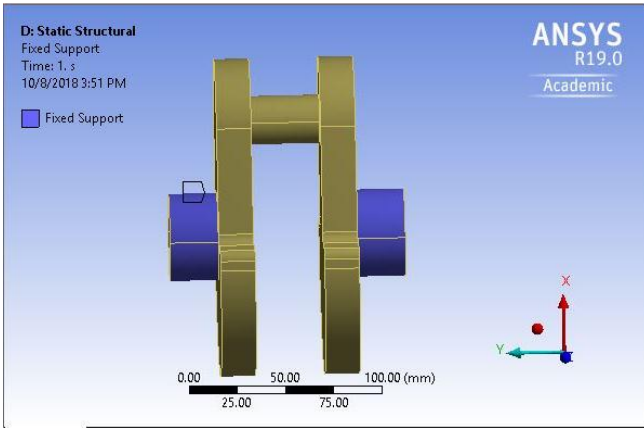

Fig.8 Fixed support of crankshaft

4. RESULT ANALYSIS

**Case-1 (Model -1)** In this case the maximum force acting on the crankpin is 22624 N.

**Deformation**

In this case 0.011156mm deformation is found.

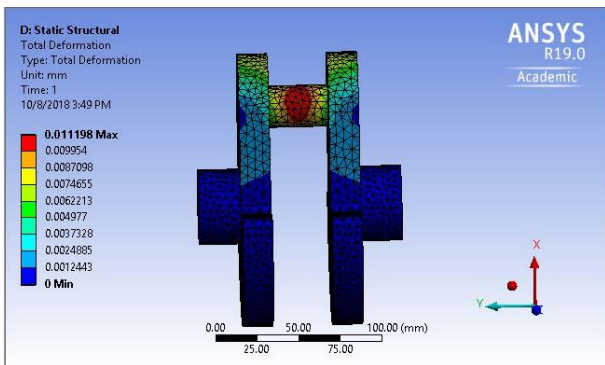

Fig.9 Total deformation in Case-1

Fig.9 represents the model 1of total deformation in case 1 when the maximum force acting on the crankpin is 22624 N. in this model min. deformation is 0 and max. deformation is 0.011198.

**Case-1 (Model-1)**

**Equivalent Stress**

In this case 68.42 Mpa maximum stresses is found.

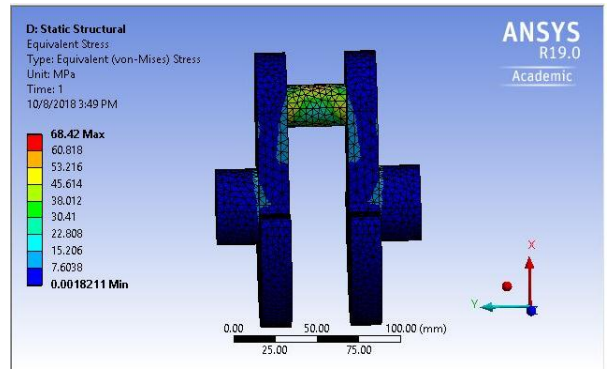

Fig.10 Equivalent stress in Case-1

Fig.10 elaborates the mode 1 of equivalent stress in case 1 when the maximum force acting on the crankpin is 22624 N. In this model min. stress is 0.0018211 and max. stress is 68.42.

The ANSYS 19.0 provide the feature of topology optimization. After applying 22624N force the new model is proposed. The red region show that this material is does not affect the all over stress value. So all the new design is made only change in red region.

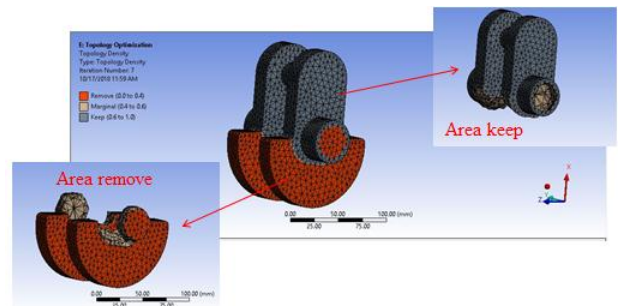

Fig.11 Topology optimization in ANSYS

**Case-1 (Model-2)**

**Deformation**

In this case 0.011182mm deformation is found.

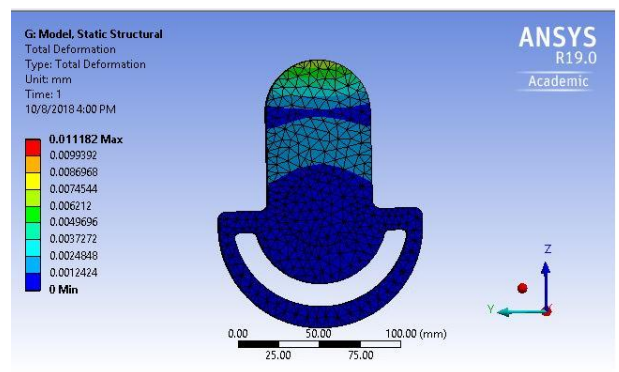

Fig.12 Total deformation in Case-1

Fig.12 shows the model 2 of total deformation in case 1 when the maximum force acting on the

crankpin is 22624 N. In this model min. deformation is 0 and max. deformation is 0.011182.

**Case-1 (Model-2)**

**Equivalent Stress**

In this case 68.70 Mpa maximum stresses are found.

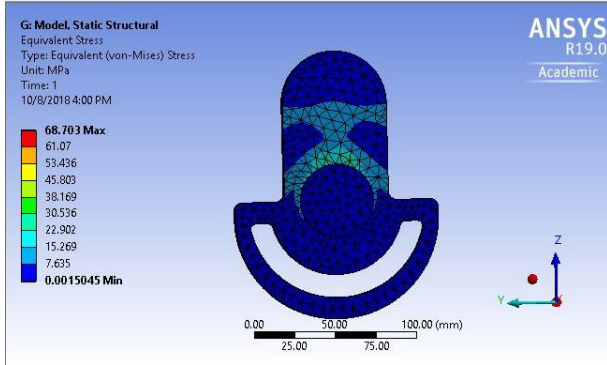

**Fig.13 Equivalent stress in Case-1**

Fig.13 represents the model 2 of equivalent stress in case1 when the maximum force acting on the crankpin is 22624 N. in this model min. stress is 0.0015045 and max. stress is 68.703.

**Case-1 (Model-3)**

**Deformation**

In this case 0.011202mm deformation is found.

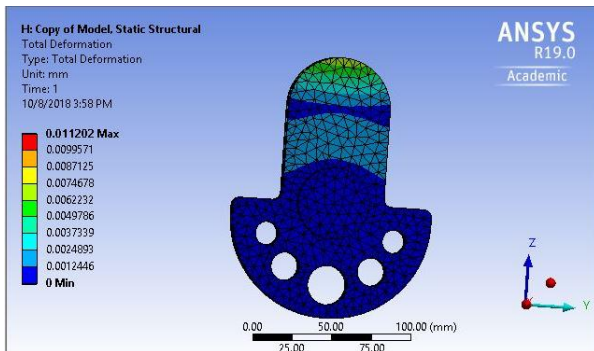

**Fig.14 Total deformation in Case-1**

Fig.14 shows the model 2 of total deformation in case 1 when the maximum force acting on the crankpin is 22624 N. In this model min. deformation is 0 and max. deformation is 0.011202.

**Case-1 (Model-3)**

**Equivalent Stress**

In this case 63.49 Mpa maximum stress is found.

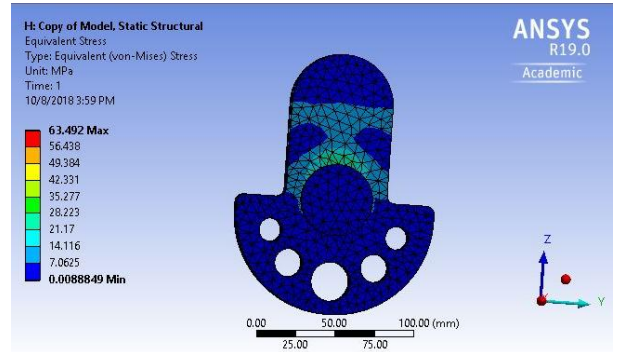

**Fig,15 Equivalent stress in Case-1**

Fig.15 represents the model 3 of equivalent stress in case 1 when the maximum force acting on the crankpin is 22624 N. In this model min. stress is 0.0068849 and max. stress is 63.492.

**Case-1 (Model-4)**

**Deformation**

In this case 0.011207mm deformation is found.

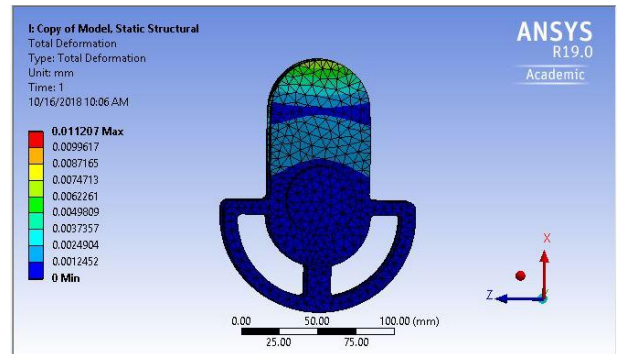

**Fig.16 Total deformation in Case-1**

Fig.16 shows the model 4 of total deformation in case 1 when the maximum force acting on the crankpin is 22624 N. In this model min. deformation is 0 and max. deformation is 0.011207.

**Case-1 (Model-4)**

**Equivalent Stress**

In this case 4 74.156 Mpa maximum stress is found.

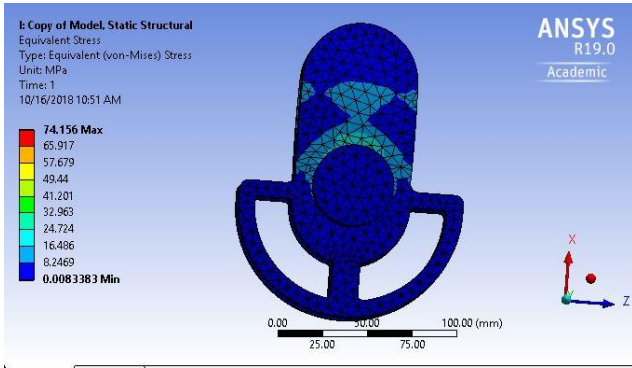

**Fig.17 Equivalent stress in Case-1**

Fig.17 shows the model 4 of equivalent stress in case 1 when the maximum force acting on the crankpin is 22624 N. In this model min. stress is 0.0083383 and max. stress is 74.156.

**Case-2 (Model-1)** In this case the maximum force acting on the crankpin is 32624 N.

**Deformation**

In this case 0.016144mm deformation is found.

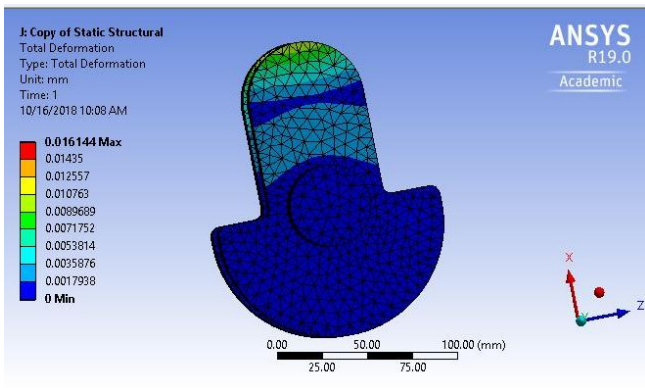

**Fig. 18 Total deformation in Case-2**

Fig.18 shows the model 1 of total deformation in case 2 when the maximum force acting on the crankpin is 32624 N. In this model min. deformation is 0 and max. deformation is 0.016144.

**Case-2 (Model-1)**

**Equivalent Stress**

In this case 98.68 Mpa maximum stress is found.

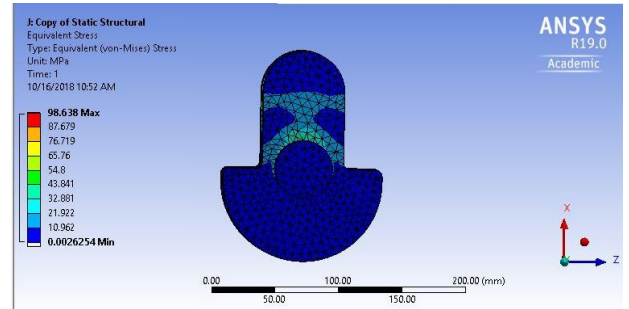

**Fig.19 Equivalent stress in Case-2**

Fig.19 shows the model 1 of equivalent stress in case 2 when the maximum force acting on the crankpin is 32624 N. In this model min. stress is 0.0026254 and max. stress is 98.638.

**Case-2 (Model-2)**

**Deformation**

In this case 0.016136mm deformation is found.

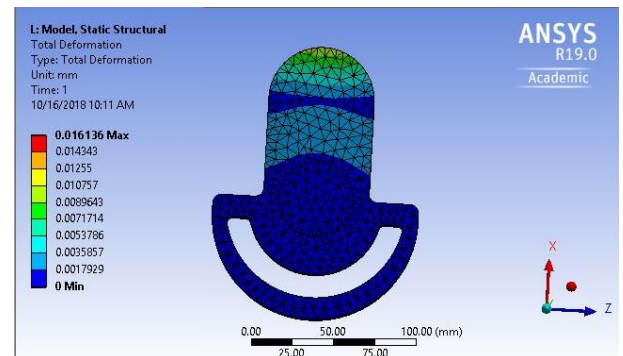

**Fig.20 Total deformation in Case-2**

Fig.20 represents the model 2 of total deformation in case 2 when the maximum force acting on the crankpin is 32624 N. In this model min. deformation is 0 and max. deformation is 0.016136.

**Case-2 (Model-2)**

**Equivalent Stress**

In this case 108.57 Mpa maximum stress is found.

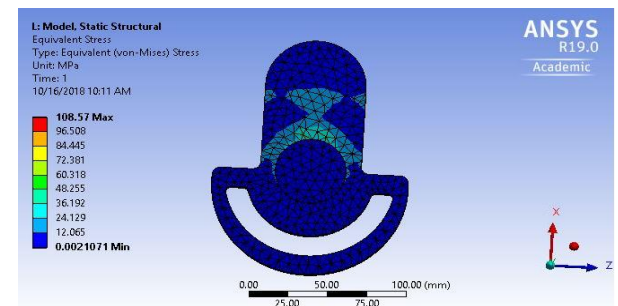

**Fig.21 Equivalent stress in Case-2**

Fig.21 shows the model 2 of equivalent stress in case 2 when the maximum force acting on the crankpin is 32624 N. in this model the min. stress is 0.0021071 and max. stress is 106.57.

**Case-2 (Model-3)**

**Deformation**

In this case 0.016149mm deformation is found.

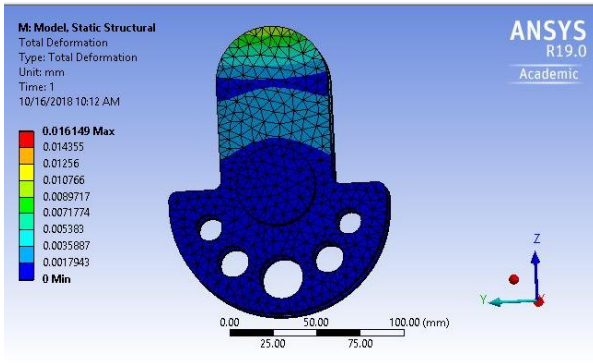

**Fig.22 Total deformation in Case-2**

Fig.22 shows the model 3 of total deformation in case 2 when the maximum force acting on the crankpin is 32624 N. In this model the min. deformation is 0 and max. deformation is 0.016149.

**Case-2 (Model-3)**

**Equivalent Stress**

In this case 91.533 Mpa maximum stress is found.

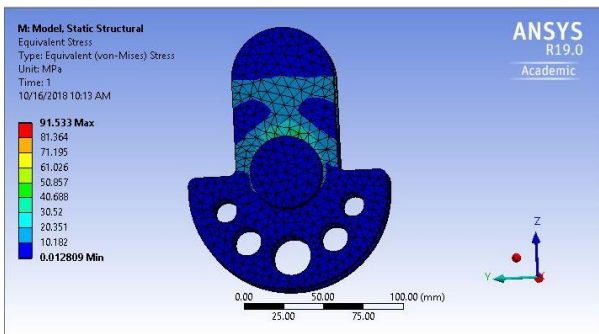

**Fig.23 Equivalent stress in Case-2**

Fig.23 shows the model 3 of equivalent stress in case 2 when the maximum force acting on the crankpin is 32624 N. in this model min. stress is 0.012809 and max. stress is 91.533.

**Case-2 (Model-4)**

**Deformation**

In this case 0.057078mm deformation is found.

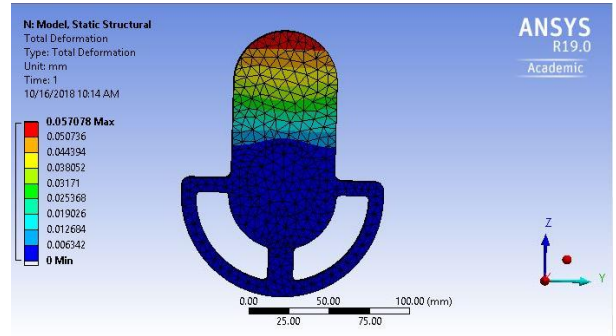

**Fig.24 Total deformation in Case-2**

Fig.24 shows the model 4 of total deformation in case 2 when the maximum force acting on the crankpin is 32624 N. In this model min. deformation is 0 and max. deformation is 0.057078.

**Case-2 (Model-4)**

**Equivalent Stress**

In this case 176.84 Mpa maximum stress is found.

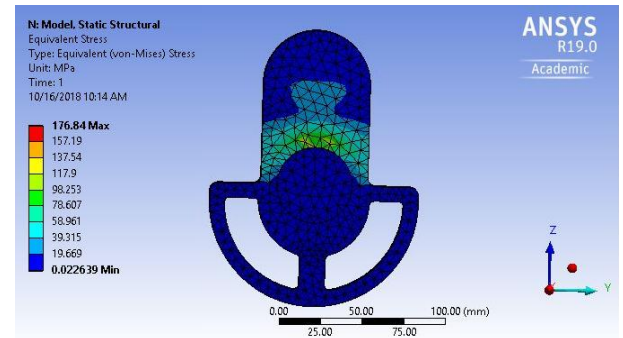

**Fig.25 Equivalent stress in Case-2**

Fig.25 shows the model 4 of equivalent stress in case 2 when the maximum force acting on the crankpin is 32624 N. In this model min. stress is 0.022639 and max. stress is 176.84.

**Case-3 (Model-1)** In this case the maximum force acting on the crankpin is 42624 N.

**Deformation**

In this case 0.02109mm deformation is found.

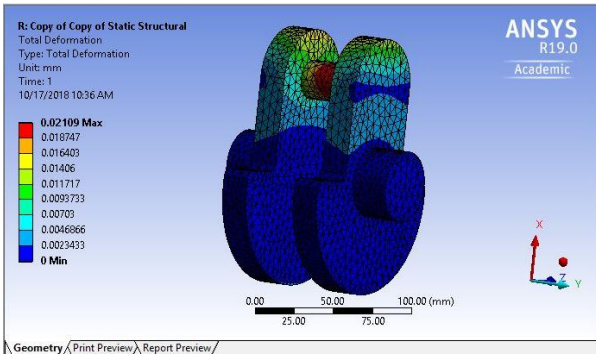

Fig.26 Total deformation in Case-3

Fig.26 elaborates the model 1 of total deformation in case 3 when the maximum force acting on the crankpin is 42624 N. In this model min. deformation is 0 and max. deformation is 0.02109.

**Case-3 (Model-1)**

**Equivalent Stress**

In this case 128.86 Mpa maximum stress is found.

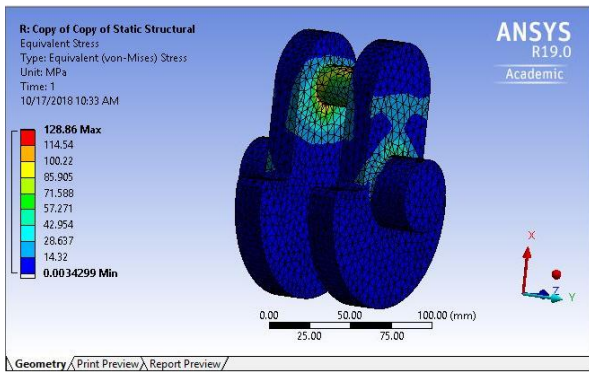

Fig.27 Equivalent stress in Case-3

Fig.27 shows the model 1 of Equivalent stress in Case-3 when the maximum force acting on the crankpin is 42624 N. In this model min. stress is 0.0034299 and max. stress is 128.86.

**Case-3 (Model-2)**

**Deformation**

In this case 0.021079mm deformation is found.

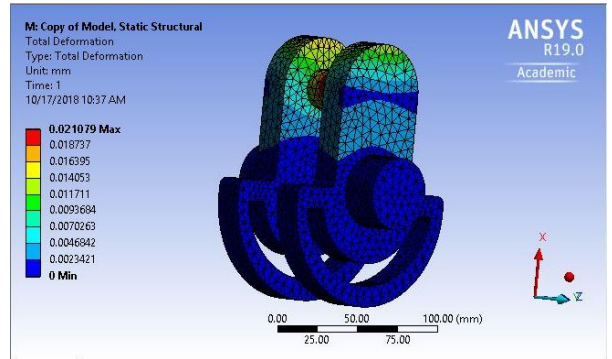

Fig.28 Total deformation in Case-3

Fig.28 show the model 2 of total deformation in case 3 when the maximum force acting on the crankpin is 42624 N. In this model min. deformation is 0 and max. deformation is 0.021079.

**Case-3 (Model-2)**

**Equivalent Stress**

In this case 148.83 Mpa maximum stress is found.

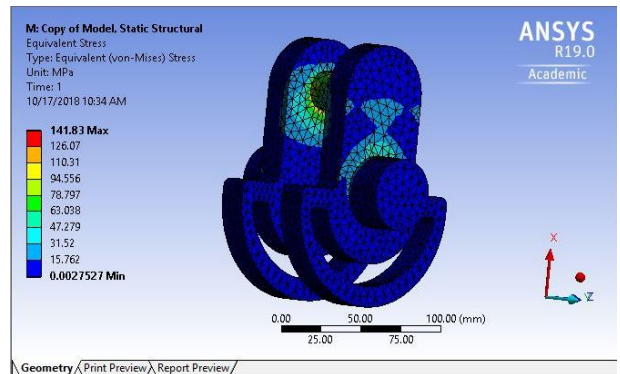

Fig.29 Equivalent stress in Case-3

Fig.29 model 2 of equivalent stress in case 3 when the maximum force acting on the crankpin is 42624 N. In this model min. stress is 0.0027527 and max. stress is 141.83.

**Case-3 (Model-3)**

**Deformation**

In this case 0.021096mm deformation is found.



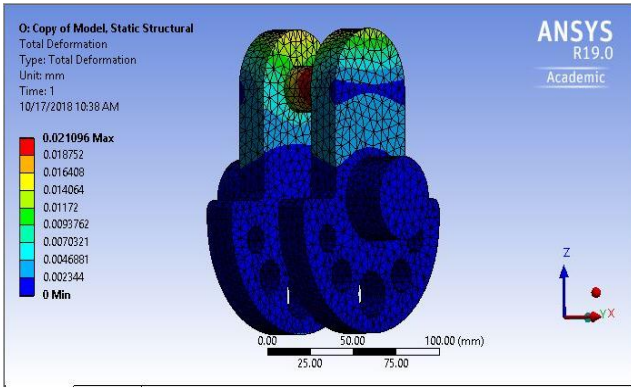

**Fig.30 Total deformation in Case-3**

Fig.30 shows the model 3 of total deformation in case 3 when the maximum force acting on the crankpin is 42624 N. In this model min. deformation is 0 and max. deformation is 0.021096.

**Case-3 (Model-3)**

**Equivalent Stress**

In this case 119.57 Mpa maximum stress is found.

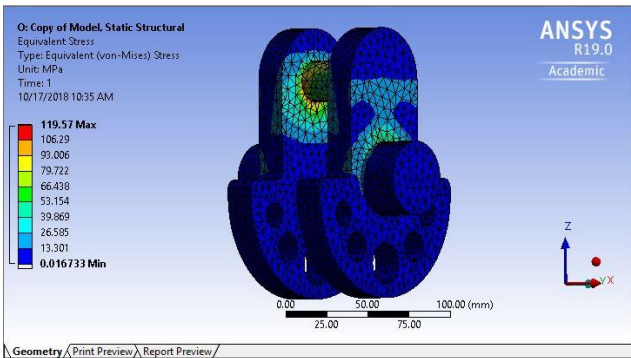

**Fig.31 Equivalent stress in Case-3**

Fig.31 shows the model 3 of equivalent stress in case 3 when the maximum force acting on the crankpin is 42624 N. In this model min. stress is 0.016733 and max. stress is 119.57.

**Case-3 (Model-4)**

**Deformation**

In this case 0.074564mm deformation is found.

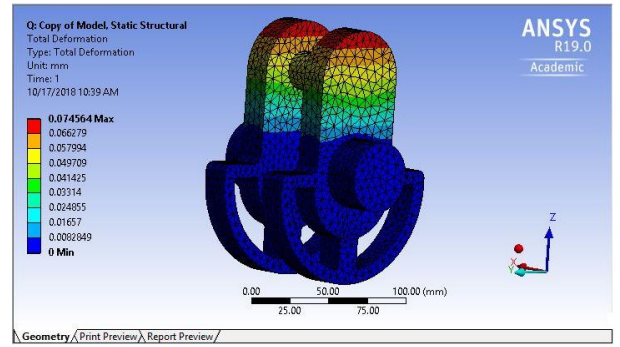

**Fig.32 Total deformation in Case-3**

Fig.32 shows the model 4 of total deformation in case 3 when the maximum force acting on the crankpin is 42624 N. In this model min. deformation is 0 and max. deformation is 0.074564.

**Case-3 (Model-4)**

**Equivalent Stress**

In this case 231.01 Mpa maximum stress is found.

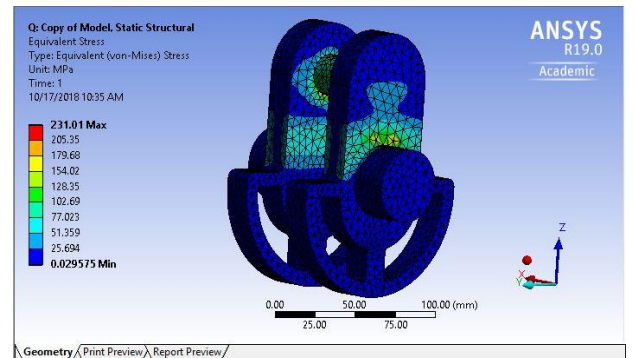

**Fig.33 Equivalent stress in Case-3**

Fig.33 shows the model 4 of equivalent stress in case 3 when the maximum force acting on the crankpin is 42624 N. In this model min. stress is 0.029575 and max. stress is 231.01.

**Deformation comparison**

After performing analysis in ansys following deformation are found as shown in table.

Table 2 Deformation comparison in all cases

Model	Case-1	Case-2	Case-3
1	0.0115	0.016144	0.02109
2	0.011182	0.016144	0.021079
3	0.011202	0.016149	0.021096
4	0.011207	0.057078	0.074564

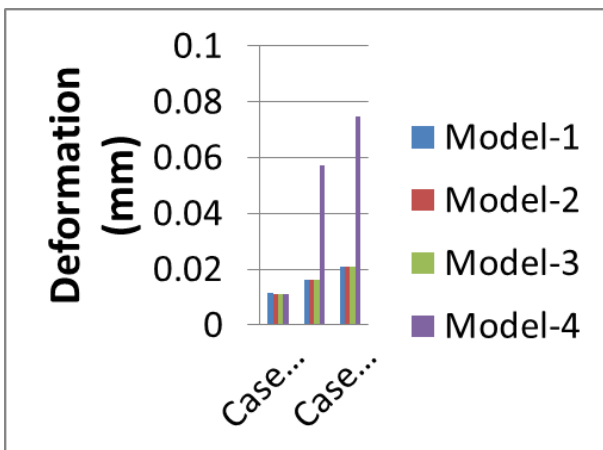

Graph 1 Deformation Comparison Graph

Graph 1 shows the comparison of deformation. In this deformation analysis there are three cases used for every four model. In this graph shows the model 4 deformation is high in case 2 and case 3. In case 1 the deformation of all model is close to each other.

**Stresses comparison**

After performing analysis in ansys following Stresses are found as shown in table.

Table 3 Stresses comparison in all cases

Model	Case-1	Case-2	Case-3
1	68.42	98.68	128.86
2	68.70	108.57	148.83
3	63.49	91.533	119.57
4	74.156	176.84	231.01

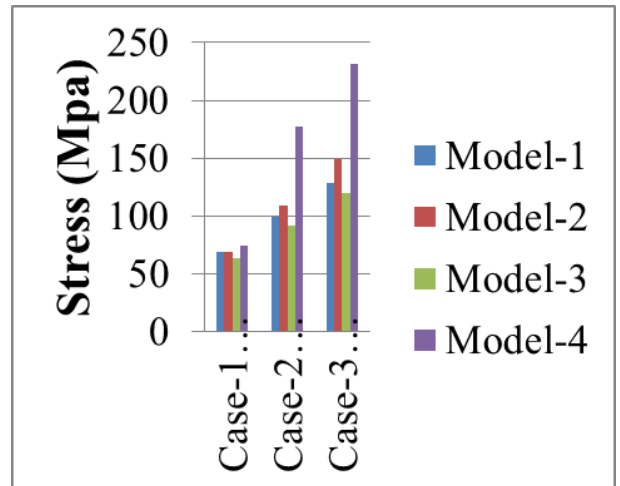

Graph 2 Stress Comparison graph

Graph 2 represents the comparison graph of stress. In this stress analysis research three case used for every four model. In every case model 4 stress is very high and model 3 stress is low.

**Weight comparison**

After performing analysis in ansys following Weight are found as shown in table.

Table 4 Weight comparison in all 3 cases

Case	Weight (Kg)
1	4.3805
2	3.854
3	3.990
4	3.6653

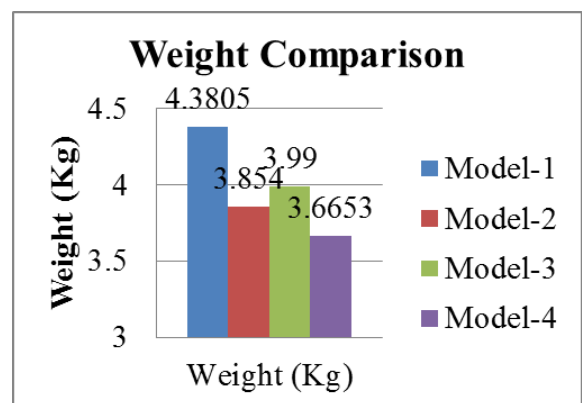

Graph 3 Weight Comparison Graph

Graph 3 represents the comparison of weight. In this graph four models of weight shows in four different colours. Model 1 weight is high and model 4 weight is lower.

## 5. CONCLUSION

Based on these analysis results, concepts have been developed which reduce the weight of the crankshaft to a possible extent, without affecting the performance of the engine. The 3D model of crankshaft system, obtained from CATIA V5 software is analyzed in ANSYS to assess the motion and loads acting on the crankshaft. Topology optimization is help to optimize the performance of any machine. The crankshaft model 3D geometry is created by using CATIA V5 and then it is import in ANSYS 19.0. and check all the result in three different load case 22624N, 32624N and 42624N.

## REFERENCES

- [1] M. Guru Bramhananda Reddy, Chanduri Rajendar Prasad, M. Uday Kiran Reddy, L. Naveen Kumar (2017). "Design & Analysis of Crankshaft by Forged Steel & Composite Material" International Journal of Engineering Trends and Technology (IJETT) – Volume - 46 Number-1 -April 2017 ISSN: 2231-5381 <http://www.ijettjournal.org>
- [2] Prashant A. Patil, D. Chanakya Gupta, Chaitanya Joshi, B Ramakrishna (2017). "DESIGN AND ANALYSIS OF CRANK SHAFT" International Journal of Professional Engineering Studies Volume VIII /Issue 5 / AUG 2017
- [3] Ketan V. Karandikar, Shailesh P. Deshpande, Sachin N. Patil, Sagar A. (2017). Deshpande, Rajendra D. Ronge - "Design, Modeling, FEM & Experimental Analysis of Crankshaft and Camshaft of a Passenger Car" ISSN (Online) 2456-1290 International Journal of Engineering Research in Mechanical and Civil Engineering (IJERMCE) Vol 2, Issue 10, October 2017
- [4] A. Pandiyan, G. Arun Kumar, B. Baskar, A. Shajin, A. Sathis Kumar and Mohammed Saleem (2016). "THERMAL EFFECT ON TOPOLOGY OPTIMIZED CRANK CASE COVER FOR ADDITIVE MANUFACTURING " ARPN Journal of Engineering and Applied Sciences VOL. 11, NO. 18.
- [5] S. Baragetti (2015). "Design Criteria for High Power Engines Crankshafts " The Open Mechanical Engineering Journal, 9, pp. 271-281.
- [6] Sujata Satish Shenkar, Nagraj Biradar (2015). "Design and Static Structural Analysis of Crank Shaft" IJSETR Vol.04, Issue.07
- [7] B. Mounika, Madhuri R. P. (2015). "Structural Static Analysis of Crankshaft" International Journal of Science and Research (IJSR) Volume 6 Issue 5
- [8] Prajakta P. Pawar, Dr. Santosh D. Dalvi, Santosh Rane, Dr. Chandra Babu Divakaran (2015). "Evaluation of Crankshaft Manufacturing Methods - An Overview of Material Removal and Additive Processes" International Research Journal of Engineering and Technology (IRJET) Volume: 02 Issue: 04.
- [9] Kanwar J. S. Gill, Pali Rosha, Subhash Chander, R. S. Bharaj (2014). "Durability Analysis of Lightweight Crankshafts Design Using Geometrically Restricted Finite Element Simulation Techniques for Camless Engines" International Conference of Advance Research and Innovation (ICARI-2014)
- [10] Momin Muhammad Zia Muhammad Idris, Prof. Vinayak H. Khatawate (2013). "Optimization of Crankshaft using Strength Analysis" International Journal of Engineering Research and Applications (IJERA) ISSN: 2248-9622 [www.ijera.com](http://www.ijera.com) Vol. 3, Issue 3, pp. 252-258.

---

### Corresponding Author

#### Dr. Rashmi Dwivedi\*

Associate Professor, Department of Mechanical Engineering, Sagar Institute of Science and Technology Bhopal