

Feeding Techniques to Improve Bandwidth of Microstrip Antenna

B. I. Kattimani^{1*}, N. K. Honnagoudar², Dr. Jagadeesha S.³

^{1 2 3} Departments of Electronics: VSMIT Nipani, Hit Nidashoshi, SDMIT Ujire

Abstract – The comprehensive study of MPA shows its important role in the modern wireless communication devices.

Detailed literature review of past few decades' papers on MPA, the MPA has emerged into wide range of communication field. Inherently the patch antenna is narrowband; various techniques were developed to enhancement of bandwidth. Different parameter affect the efficiency of antenna .Specification of MPA has low weight, low profile. This is Omni-directional antenna whose fabrication is easy.

Index Terms— Patch Design, Electromagnetic Wave, and Radiation, Microstrip, Antenna

I. INTRODUCTION

Antenna is also called as transducer which transceivers electromagnetic waves. Micro strip contains a patch which is called as radiating patch. Various feed techniques has been compared & it was found that co-axial feed is best among all, & provide better performance. The size of antenna increases due to the physical dimensions on the edge. Resonant condition is obtained by using less than half the wavelength of micro strip line. Lithographic pattern is used to design patch on the dielectric substrate ($\epsilon_r \leq 10$). Microstrip patch antenna are basically work on narrowband various bandwidth enhancement techniques has been introduced to increase the bandwidth [1].

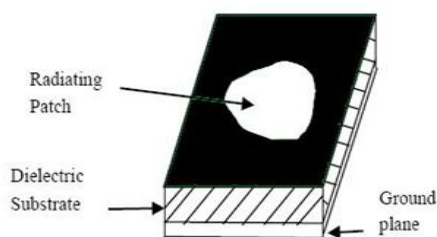

Fig. 1 Micro strip patch antenna

II. MICROSTRIP PATCH CONFIGURATION

A. Microstrip Patch Antenna

A micro strip patch antenna has a patch which is conducting in nature .The geometry of conducting patch is of planar & non-planar nature. The structures of microstrip patch antenna have dielectric substrate

on one side & ground plane on other side.MPA requires semi-hemispherical coverage for narrowband microwave wireless links.MPA planar configuration & ease of integration is widely used as array elements. The patch used in MPA is of different shape and structure which shows different properties of radiation. Among all structure generally rectangular and circular patch are preferred. Due to their structure which can easily separated & simple estimation rectangular patch is used in various applications. While the circular patch antenna shows symmetric radiation pattern. The length of patch L is given by the following expression:

$$L \approx 0.49 \lambda_d = \frac{0.49 \lambda_d}{\sqrt{\epsilon_r}}$$

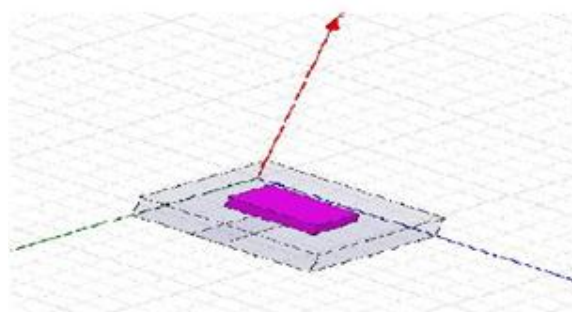

Fig 2 Micro strip patch antenna

B. Microstrip or Printed Dipole Antenna

The basic difference in the MPA & printed dipole antenna is in their length-to-width ratio. The dipoles

used in the printed dipole antenna have $0.05\lambda_0$ times width [2]. Different parameter such as radiation resistance, bandwidth, and cross-polar radiation vary according to the width of dipole used. The main advantage of dipole antenna that is best for higher frequencies and the requirement for attaining significant bandwidth the substrates used must be electrically thick. The VSWR is normally 2 in dipole antenna.

Feeding Technique to Improve Bandwidth of MPA

The excitations of the radiating patch depend upon the feed current & patch mode.

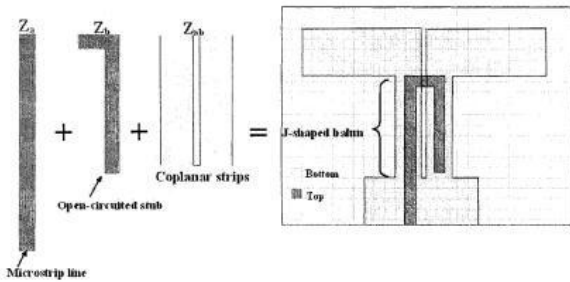

Fig 3 Micro strip Dipole Antenna

C. Printed Slot Antenna

The structures of Printed slot antenna consist of a slot in the ground plane of a grounded substrate. Many of MPA are analyze in the form of printed slot antenna theoretically. Among many design few are of most use namely rectangular slot, annular slot, rectangular ring slot & tapered slot. Feeding techniques can be micro strip line or co-planar waveguide. The specific features of slot antenna are generally bidirectional radiators & they radiate on both side of slot.

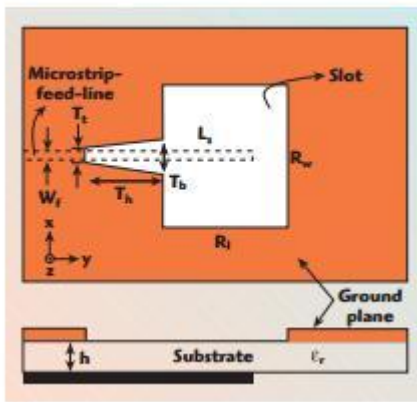

Fig 4 Geometry of Printed Slot Antenna

D. Micro Strip Travelling Wave Antenna

A MPA contain a chain-shape conductor which is periodic in nature & to support TE mode a feed of long micro strip line is used. At the other end resistive load is matched to the traveling wave antenna so as to neglect the standing wave which appears on antenna. This traveling wave is so formed that must lie in any direction from broad side to end fire.

III. FEEDING TECHNIQUES

Feeding is a techniques in which excitation is provided by the direct or indirect contact to make the patch radiate.

A. Co-axial Probe Feed

Co-axial probe feeding is provided by direct contact. The structure of co-axial probe feeding consists of two conductors [4]. The inner conductor is attached with patch and the outer conductor is attached to the ground plane. The fig 3 shows the diagram of this by hfss software there are few advantages of this is that the fabrication impedance matching is easy. The increases in probe length result in more inductive input impedance due to which impedance matching problem occur.

$$\iiint v E_z J_z \approx \cos \pi \frac{x_0}{L}$$

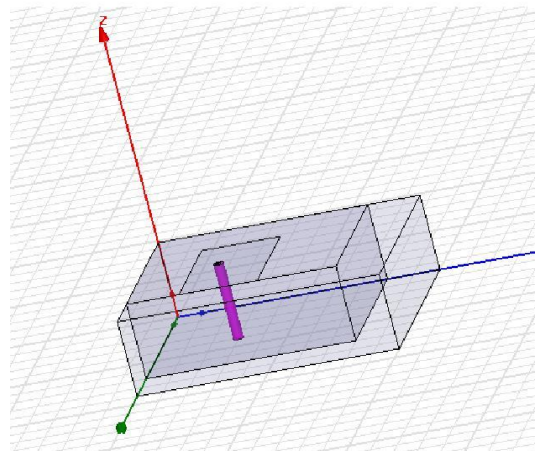

Fig 5 Co-axial Probe Feed

B. Micro Strip Line Feed

A Micro strip line is a simple conducting strip which is directly connects to the radiating patch [3]. Micro strip lines are easy in fabrication, matching by means of controlling the position of the microstrip line. The fig 4 shows the diagram of this by hfss software .Main disadvantages are thickness of substrates is increase. High spurious radiation & surface wave narrowband. If we increase the thickness of dielectric substrate the corresponding surface wave & spurious radiation will also increase. The patch is excited by the edged coupled micro strip line with current density J_z & H_y as magnetic field.

$$\text{Coupling} \approx \iiint v E_z J_z dv \approx \cos(\pi X_0/L)$$

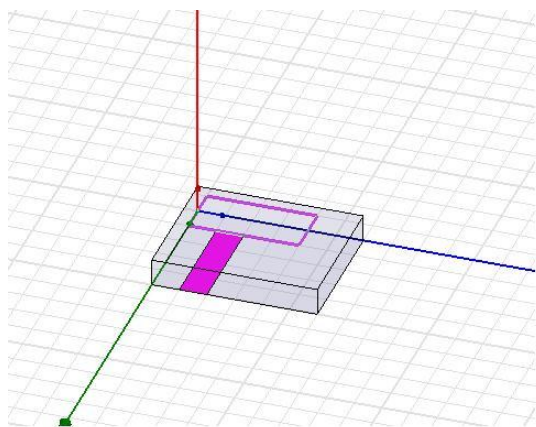

Fig 6 Micro strip line feed

C. Aperture Coupled Feed

Aperture coupling feed consist of two dielectric substrates. Both dielectric have different dielectric constant & are separated by ground plane. The fig 5 shows the diagram of this by hfss software. The top dielectric substrate constant is high. The ground plane in between these two dielectric substrates is used for the isolation of the feed from the radiation of the radiating patch. The line feed & lower substrate are electromagnetically coupled to the patch through the aperture. Coupling depends on size, shape & location of aperture.

$$\text{Coupling} = \iiint v M \cdot H dv \approx \sin(\pi X_0/l)$$

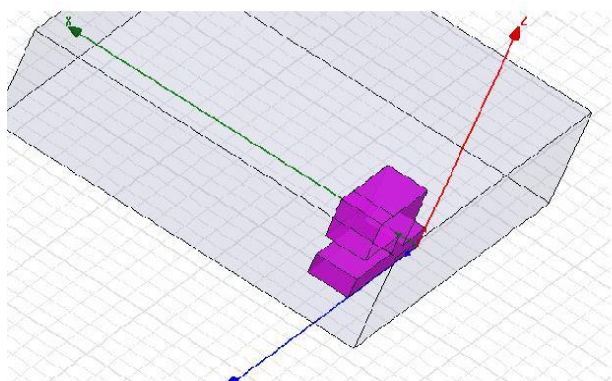

Fig 7 Aperture Coupled Feed

D. Proximity Coupling Feed

Proximity is non-conducting type of feed technique. The fig 8 shows the diagram of this by hfss software. In this particular configuration, the impedance matching is controlled by length of feeding stub

& width-to-length ratio [5]. The coupling in the proximity is of capacitive in nature. It have double layer of dielectric substrate on which the radiating patch is placed due to which bandwidth is enhanced.

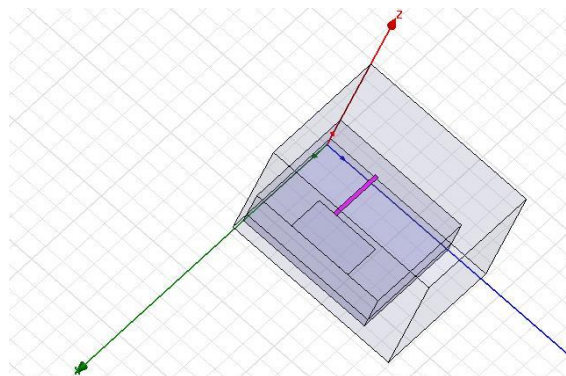

Fig 8 Proximity Coupling Feed

IV. MICROSTRIP ANTENNA CHARACTERISTICS

Many characteristics such as radiation patterns, gain & beam width affect the micro strip patch antenna behavior but apart from these there are some other parameters which play very important role in the calculation of MPA.

V. CONCLUSION

This paper presents a survey of the different structures used to accomplish the behavior of MPA by HFSS. By introducing slots in the patch, the dual-frequency operation can be achieved in a rectangular patch antenna. This dual-frequency operation is not accomplished at the expense of any other feature such as cross polarization or distorted radiation patterns.

REFERENCES

- Ramesh Garg, Prakash Bartia, Inder Bahl, Apisak Ittipiboon, "Microstrip Antenna Design Handbook", 2001, pp 1-68, 253-316 Artech House Inc. Norwood, MA.
- Alla I. Abunjaileh, Ian C. Hunter, Andrew H. Kemp, "Multi-Band Matching Technique for Microstrip Patch Antenna Receivers", School of electronic and electrical engineering, The University of Leeds" IEEE, EUMC.2007.4405174.
- Yasir Ahmed, Yang Hao and Clive Parini, "A 31.5 GHZ Patch Antenna Design for Medical Implants", University of London, International Journal of Antennas & Propagation", volume 2008, (2008), article ID 167980.

S. Sathamsakul, N. Anantrasirichai, C. Benjangkaprasert, and T. Wakabayashi, "Rectangular Patch Antenna with inset feed and modifier ground plane for wide band antennas", IEEE, Aug, 2008.

Richard C. Johnson, Henry Jasik, „Antenna Engineering Handbook” Second Edition 1984, pp 7-1 to 7-14, McGraw Hill, Inc. NY, USA.

Pozar, D. M., „Microstrip Antennas”, Proc. IEEE, Vol. 80, 1992, pp. 79- 91

Corresponding Author

B. I. Kattimani*

Departments of Electronics: VSMIT Nipani, Hit Nidashoshi, SDMIT Ujire

E-Mail – navyabk2012@gmail.com